

XMT-32 TRANSMITTER CONTROLLER MANUAL

Zonge International

3322 East Fort Lowell Road, Tucson, AZ 85716 USA
Tel:(520) 327-5501 Fax:(520) 325-1588 Email:zonge@zonge.com

Blank Page

TABLE OF CONTENTS

| | |
|--|----|
| Transmitter Controller Specifications | 5 |
| General Description | 5 |
| Controls & Displays..... | 5 |
| Outputs & Inputs..... | 5 |
| Functions..... | 5 |
| Transmitter Control Interface | 6 |
| Transmitter Control MS Connector | 6 |
| Synchronizing Timing Circuits | 8 |
| Frequency Adjust and Synchronizing Operations | 8 |
| Synchronizing The Transmitter And Receiver | 11 |
| At least one hour prior to adjusting the frequency..... | 11 |
| After crystal ovens have heated for at least 60 minutes..... | 12 |
| Manually Trim The XMT | 15 |
| Set the Crystal adjustment on the GDP to Mid-Range | 15 |
| Manually trim the oscillator in the XMT-32..... | 15 |
| Losing Synchronization | 16 |
| Synchronization can be lost | 16 |
| Synchronization is not lost..... | 16 |
| Synchronizing Multiple Receivers | 18 |
| With the MULTI/SY-16 Sync. Box..... | 18 |
| With the MULT/SY-32 Sync. Box | 20 |
| Synchronizing An Additional XMT | 21 |
| Check the synchronization..... | 21 |
| Time Schedule Operations | 22 |
| XMT-32S Time Schedule | 22 |
| Equipment Needed..... | 22 |
| Procedure | 22 |
| Mechanical Adjustment of Crystals | 23 |
| Mechanical Adjustment of XMT-32 Crystal | 23 |
| Mechanical Adjustment of small case GDP-32 Crystal | 24 |
| Mechanical Adjustment of large case GDP-32 Crystal | 25 |

NOTE: This manual has been assembled using sections of the GDP-32 Manual. Figure numbers from the GDP-32 Manual have been used, unmodified.

Blank Page

XMT-32 TRANSMITTER CONTROLLER SPECIFICATIONS

(GDP-32 Manual, Section 18.5)

GENERAL DESCRIPTION

Microprocessor controlled with memory for storing time schedule look-up tables for automatic transmitter control.

Synchronous time-base with internal calibrator.

Time or Frequency domain capability, 50% or 100% Duty cycle.

Frequency range in Binary Steps: 1024 Seconds to 8192 Hz

Size: 28x21x18 cm (11x8x7 in)

Weight: 6.4 kg (14 lb)

Enclosure: Heavy duty, environmentally sealed aluminum case.

Power: 12 V rechargeable battery, more than 10 hours continuous operation

Temperature range: -40° to +60°C (-40° to +140°F)

Humidity range: 0 to 95% non-condensing

Time base: Oven-controlled crystal oscillator;

aging rate $<5 \times 10^{-10}$ per 24 hours

(optional crystal: 1×10^{-11} per 24 hours.)

CONTROLS & DISPLAYS

Phase/Battery meter

Time/Frequency switch

Battery/Phase meter switch

High/Low range calibrate output switch

.025/.25/2.5V PP

Reset switch

LCD Frequency display

Circuit Breaker.

OUTPUTS & INPUTS

12V Battery charge input

Control input/output

Calibrate output

RS232 input for time sequence table

FUNCTIONS

Can be synchronized with GDP-32 Receiver for synchronous measurements. Capable of controlling GGT-series and ZT- and NT-series transmitters in both time and frequency domain. Continuous phase coherency between 1024 second period and 8192 Hz. 20 milliamp control signal for transmitter control. Reset pulse output for GDP-series receiver.

TRANSMITTER CONTROL INTERFACE

(GDP-32 Manual, Section 18.6)

The GGT series transmitters use a twenty milliamp control signal with a rise and fall time of less than one microsecond. There are two control signals used; Transmitter on/off and Polarity.

1. **TRANSMITTER ON/OFF.** This signal is used in the time domain mode to turn off the transmitter when needed depending on the duty cycle required.
2. **POLARITY.** This signal controls the output polarity of the transmitter. When the signal is supplied the transmitter reverses the output polarity from the rest state.

The timing diagram below shows the relationship between the two signals for a fifty percent duty cycle.

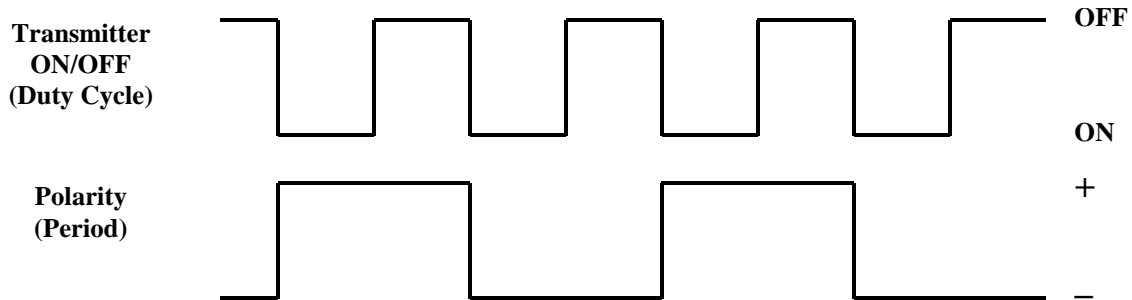

Presently we use a National Semiconductor chip to provide the drive for the transmitter from both the transmitter controller and the receiver. This MM88C3ON chip is used with either a 180 ohm or 560 ohm resistor in the output, depending on whether it is interfaced to 5 volt or 12 volt logic. This limits the current to a maximum of twenty milliamps in the drive circuits. The speed of the chip is more than sufficient to provide the proper drive.

Transmitter Control MS Connector

Polarity: A
Ground: B, E (Need to be shorted together)
Transmitter ON/OFF: C (With no connection, default is ON)
Duty cycle: D

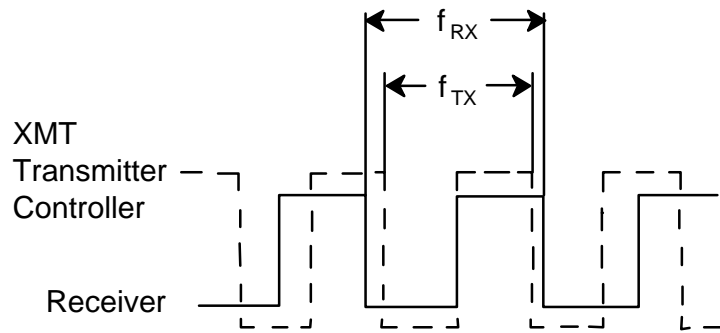

a) Initial State:
signal frequency from receiver and controller crystals are different

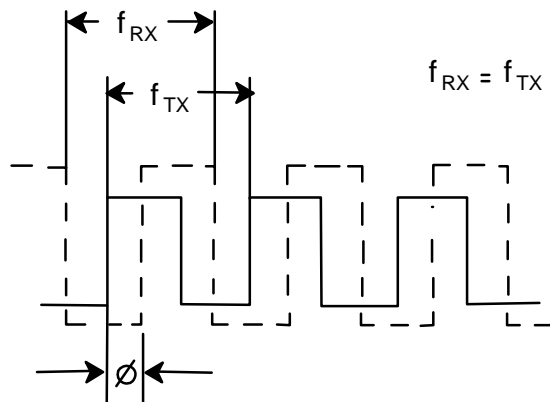

b) After Trimming Oscillator:
signal frequencies are now the same but are out of Phase by ϕ

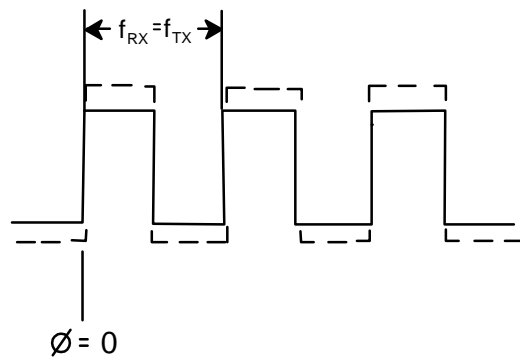

c) After Pressing RESET on XMT:
receiver and controller divider chains now at same frequency and in phase synchronization

Fig. 2.4. Pictorial description of the frequency adjust and synchronizing operations.

SYNCHRONIZING TIMING CIRCUITS

(GDP-32 Manual, Section 6.2)

Frequency Adjust and Synchronizing Operations

The timing circuits of the XMT-32 and the GDP-32 are comprised of an ultra-stabilized 4.980736 MHz oscillator and a digital counter chain providing a binary sequence of frequency divisions. Frequencies on the XMT transmitter controller are selectable from a push-button panel switch. Frequencies on the GDP are selectable from a menu screen under the control of the on-board computer.

To ensure that the timing edge of the transmitter controller (i.e. the transmitter output) and the receiver waveforms coincide exactly throughout the day, two adjustments must be made:

- First, the two 4.980736 MHz crystals must be adjusted to EXACTLY the same frequency to prevent the phase drift.
- Second, the counter chains in the XMT and GDP-32 must be reset so that the switching edges of both occur simultaneously (i.e. the waveforms are synchronized.)

The GDP uses the counter waveform to determine the polarity of the transmitted waveform and the on/off cycle in the case of time domain. Both of these adjustments require that the synchronization cable be connected between the XMT and GDP-32.

The synchronization cable connects the GDP-32 4.980736 MHz oscillator output to the XMT phase detector. The detector displays the frequency difference between the two oscillators on the XMT meter. Each complete swing of the meter represents one cycle of 4.980736 MHz or 0.2 microseconds (μsec) of time shift.

The following table shows the phase shift in milliradians (mr) per meter swing that occur at various frequencies, where:

| | | | |
|--|-----------------------|--------------------------|-----------------|
| <u>Period</u> = 1/ <u>Frequency</u> | | | |
| <u>Period/mr</u> = <u>Period</u> /(6.283*1000) | | | |
| <u>Freq</u> | <u>Period</u> | <u>Period/mr</u> | <u>mr/swing</u> |
| 8192. Hz | 122.0 μsec | 0.019 $\mu\text{sec/mr}$ | 10.5 mr/swing |
| 512. | 1953.0 | 0.31 | 0.62 |
| 64. | 15.6 msec | 2.5 | 0.08 |
| 8. | 125.0 | 19.9 | 0.01 |
| 1. | 1.0 sec | 159.0 | 0.00125 |
| 0.125 | 8.0 | 1.3 msec/mr | 0.00016 |

The above list shows the importance of accurate frequency adjustments for the acquisition of accurate high frequency phase measurements. The frequency match is obtained by performing a **Frequency Adjustment** as outlined in the section below. Typically, the frequency should be adjusted so that meter drift is less than one division over a 30 second interval. Drift rates of this magnitude yield phase drifts of less than one hundredth of the above values.

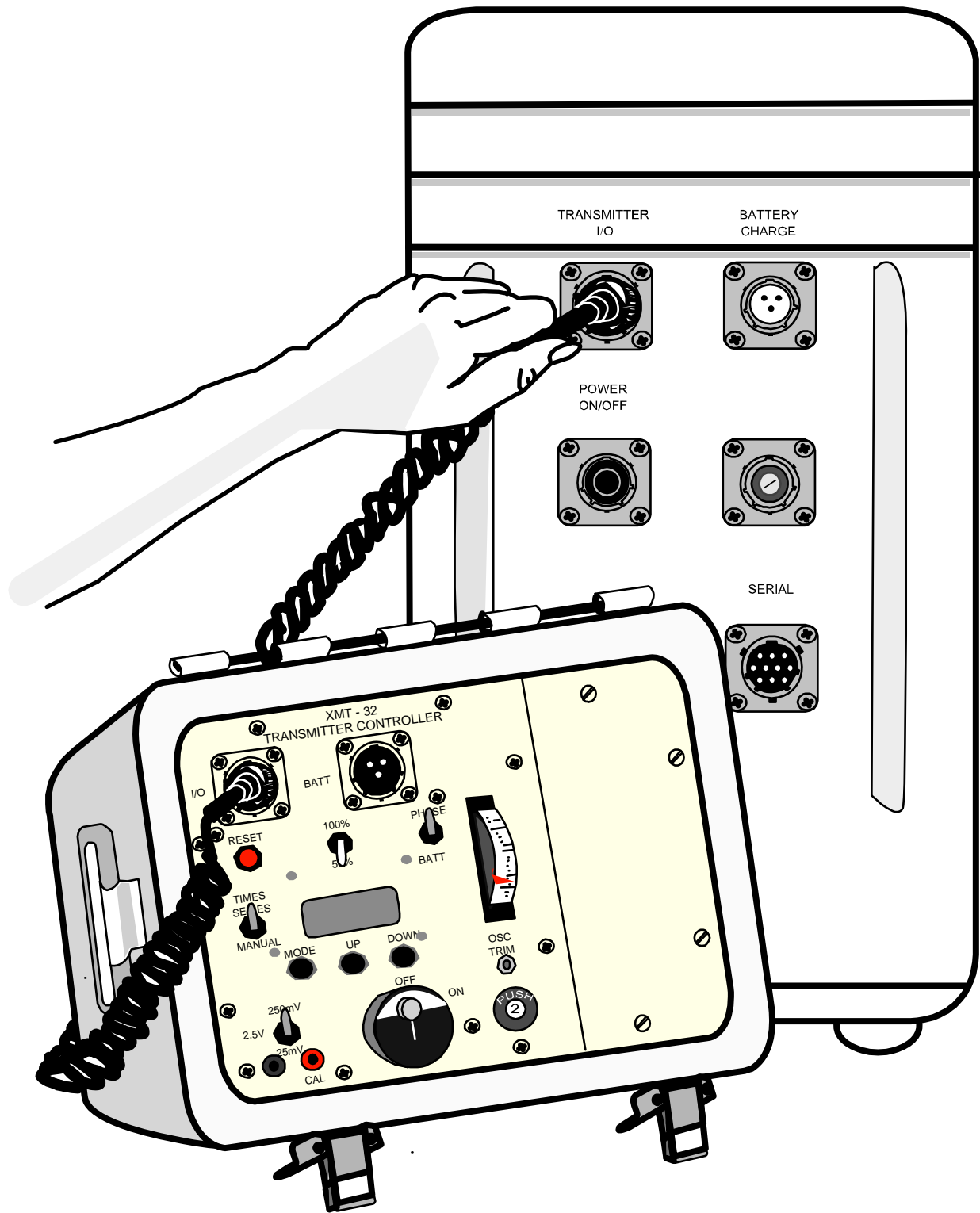

Fig. 2.5 (6.3). Connecting the GDP-32 Receiver and XMT Transmitter Controller for synchronization.

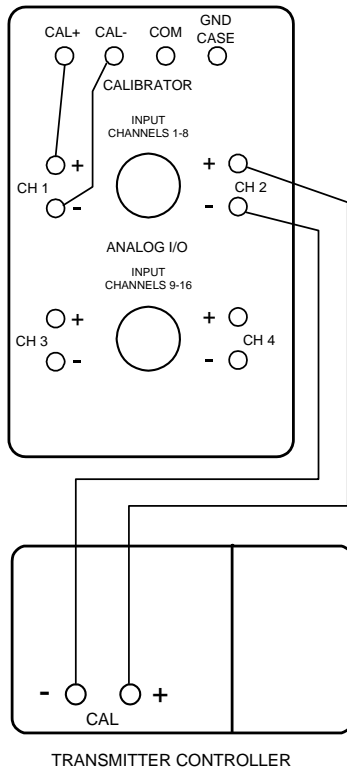

Figure 6.4(a) - Wiring for verifying synchronization to a small case GDP-32

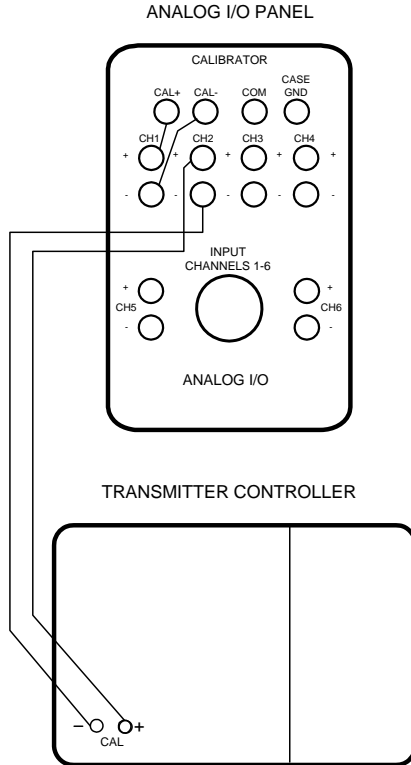

Figure 6.4(b) - Wiring for verifying synchronization to a large case GDP-32

The synchronization cable also connects and enables the counter chain reset circuitry in both the GDP and XMT.

After the frequency adjustment is made, align the counter edges by pressing **RESET** on the XMT transmitter controller. RESET places the counters in both instruments in the reset mode (positive output) where they both remain until the **RESET** button is released. When RESET is released, both counters simultaneously start to count thereby providing synchronized frequency waveforms that can be selected from the GDP and XMT.

Refer to Figure 6.3 for a pictorial description of the frequency adjust and synchronization operations.

SYNCHRONIZING THE TRANSMITTER AND RECEIVER

The GDP receiver and XMT transmitter controller have identical crystal oscillators and circuitry for dividing the crystal frequency into a set of precise, selectable, operational frequencies. For synchronous operation, the two oscillators must resonate in frequency to provide an absolute phase reference.

NOTE: For surveys such as complex resistivity (CR), roll-along IP, and NanoTEM where the receiver is linked to the transmitter directly, synchronization is not required. The receiver clock controls both the transmitter and the receiver.

At least one hour prior to adjusting the frequency:

1. Press the Power On/Off Button on left side panel of the GDP-32 to apply power to the crystal oscillator. Make sure that the red LED marked CRYSTAL is illuminated.
2. Turn the Power Switch on the XMT-32 to ON.

NOTE: During continuous field operations, power to either the GDP-32 or the XMT-32 crystals should rarely be turned off. In this way there is no need to wait for the crystal ovens to warm up.

CAUTION: Before using the 'Synchronize to XMT' routine or the manual synchronization routine, make sure you have a good calibration for the RPIP as that program is used in the synchronization routine.

After the crystal ovens have heated for at least 60 minutes:
(GDP-32 Manual, Section 3.6)

1. Disconnect the Battery Charger.
2. Connect the synchronization cable between the I/O port on the transmitter controller XMT-32 and the TRANSMITTER I/O port on the Control I/O panel of the receiver (Figure 6.4.)
3. Switch the PHASE/BATT switch to the BATT position to check the transmitter controller battery voltage. The voltage should read at least 12.5 volts. If lower, there is either a poorly charged battery or a problem with the power system (*GDP-32 Manual, Section 15 - Maintenance.*)
4. Switch the PHASE/BATT switch to the PHASE position. Observe the needle on the PHASE/BATT analog meter. Any needle movement indicates that there is some frequency difference between the GDP-32 and the XMT-32 oscillators.

The faster the needle is swinging, the greater the frequency difference. If there is absolutely no swinging over a period of a minute or so, the oscillators are either adjusted to the exact same frequency, or the oscillators are very different in frequency and the resultant beat frequency is beyond the response of the meter.

Frequency adjustment and synchronization are accomplished with the GDP-32 by executing the "Synchronize to XMT" function (Utilities Menu - Option 4.)

5. Follow the directions given on the screen:

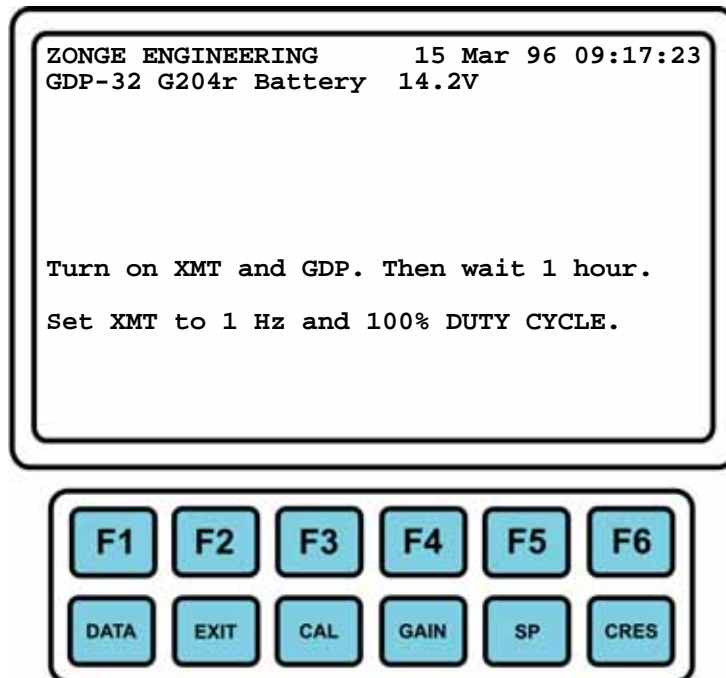

6. Press **CONTINUE**.

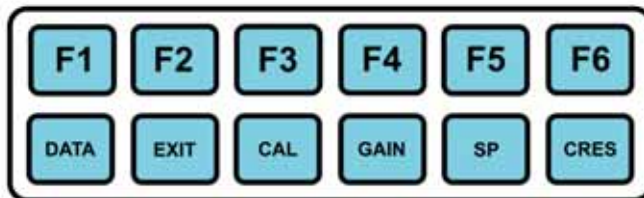
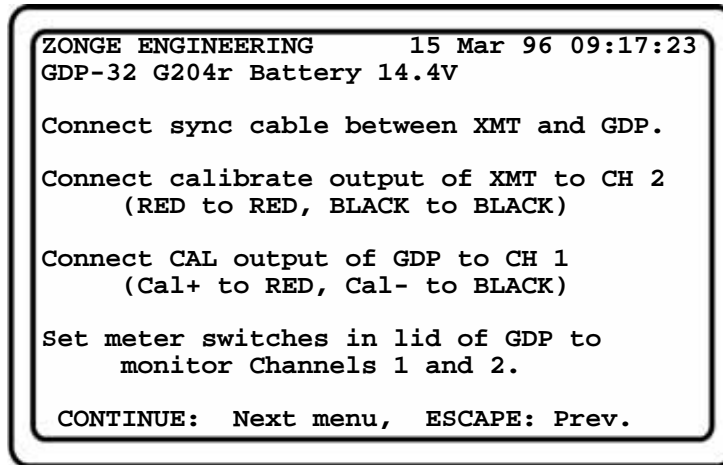

7. Continue to follow screen instructions for external connections: (see Figure 6.4)
8. Press **CONTINUE** when the connections have been completed.
9. To electronically adjust the crystal frequency of the GDP-32 to match that of the XMT-32 use the cursor control keys and follow the instructions on the display:

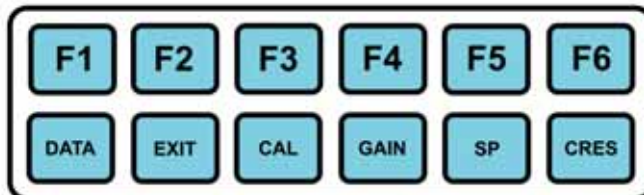
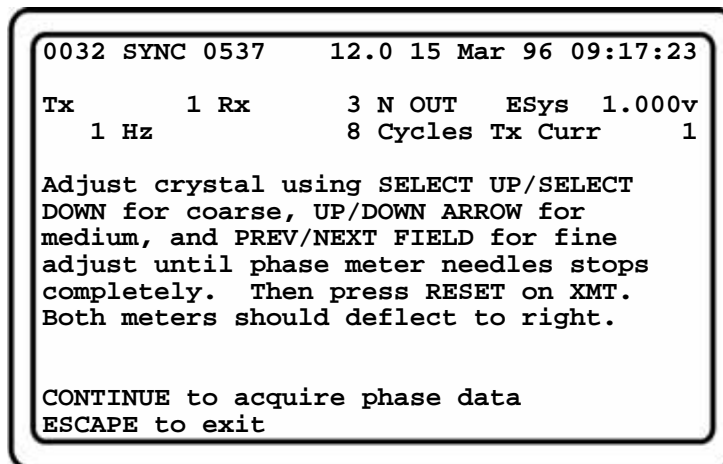

While adjusting the frequency of either instrument, the needle should come to rest near the center of the meter, where it is most sensitive to movement. Use the cursor control keys to adjust the frequency up or down slightly until the needle roughly stabilizes near the center of the scale.

10. Press **RESET** to synchronize the counter chains of the two instruments. (When synchronizing multiple receivers proceed to step 12.)
11. Press **CONTINUE**. The GDP-32 automatically measures the phase difference between the external calibration signal generated by the GDP-32 and the corresponding signal generated by the XMT-32. If the two instruments have been properly synchronized, the measured phase difference is close to 0.0 mr.
12. Repeat step 11 several times to check the synchronization. The measured phase difference should remain close to 0.0 mr.
13. Ensure that synchronization can be maintained by disconnecting the synchronization cable and repeating the phase measurement.

MANUALLY TRIM THE XMT (GDP-32 Manual, Section 17.6)

In extreme cases, the frequency difference between the two oscillators is too large to adjust out electronically. In this case, manually trim the oscillator on the XMT using a plastic trimming tool or a small, insulated, flat-bladed screwdriver.

NOTE: The GDP-32 crystal adjustment potentiometer is not externally accessible. It is unlikely that a customer would need to trim both oscillators.

There are approximately 70 coarse divisions for crystal adjustment of the GDP-32. Before adjusting the trim pot in the XMT, set the coarse adjustment on the GDP-32 to mid-range.

Set the Crystal adjustment on the GDP to Mid-Range:

1. Hold down one of the coarse adjustment keys (**SELECT UP** or **SELECT DOWN**) until you hear a rapid beep.
2. Press the opposite button 35 times (35 beeps) to set the coarse adjustment to mid-range.

Manually trim the oscillator in the XMT-32:

1. Locate the OSC TRIM potentiometer adjustment screw on the panel of the XMT-32 (Figure 6.3.)
2. Make sure the meter function switch is in the PHASE position.
3. Using a plastic adjustment tool, turn the trim pot screw slowly in one direction and observe the response on the XMT-32 meter.
4. If the needle motion slows down, the screw is being turned in the correct direction. If it speeds up, turn it the other direction. Keep turning the screw until the needle movement comes to a stop.
5. If the PHASE needle still does not stop after adjusting both crystal oscillators, it will be necessary to mechanically adjust the crystals in either the GDP-32 or XMT. Consult a Zonge engineer before attempting this procedure.
6. While adjusting the frequency of either instrument, cause the needle to come to rest near the center of the meter, where it is most sensitive to movement. Use the cursor control keys to adjust the frequency up or down slightly until the needle roughly stabilizes near the center of the scale.
7. Using the fine adjustments on the GDP-32, trim the frequency until meter movement halts. The oscillator is properly adjusted if the needle drifts less than the distance between two meter marks over a 30 second interval.

CAUTION: Before using the 'Synchronize to XMT' routine make sure you have a good calibration for the RPIP program (FDCALS in the CALIBRATION cache), since that program is used in the synchronization routine.

LOSING SYNCHRONIZATION

Synchronization can be lost in the following circumstances:

- Turning off power
- Losing battery power to either the transmitter controller or the receiver
- Re-adjusting the OSC TRIM pot on the transmitter controller
- Malfunction of the timing chain, crystal heater, crystal, timing boards, etc.
- The GDP or XMT receives a sharp jolt

Synchronization is not lost in the following circumstances:

- Turning off the receiver using Utilities Menu Option 6 – Turn Off Power.
- Re-booting the machine with the SHIFT/RESET sequence
- Changing frequencies
- Changing from time domain to frequency domain or vice versa.

If synchronization is lost, connect the controller and the receiver using the synchronization cable and re-synchronize. In certain cases, such as in scalar CSAMT, you may be able to avoid this if you are interested only in phase difference between the electric and magnetic field components. Usually, loss of synchronization must be corrected immediately.

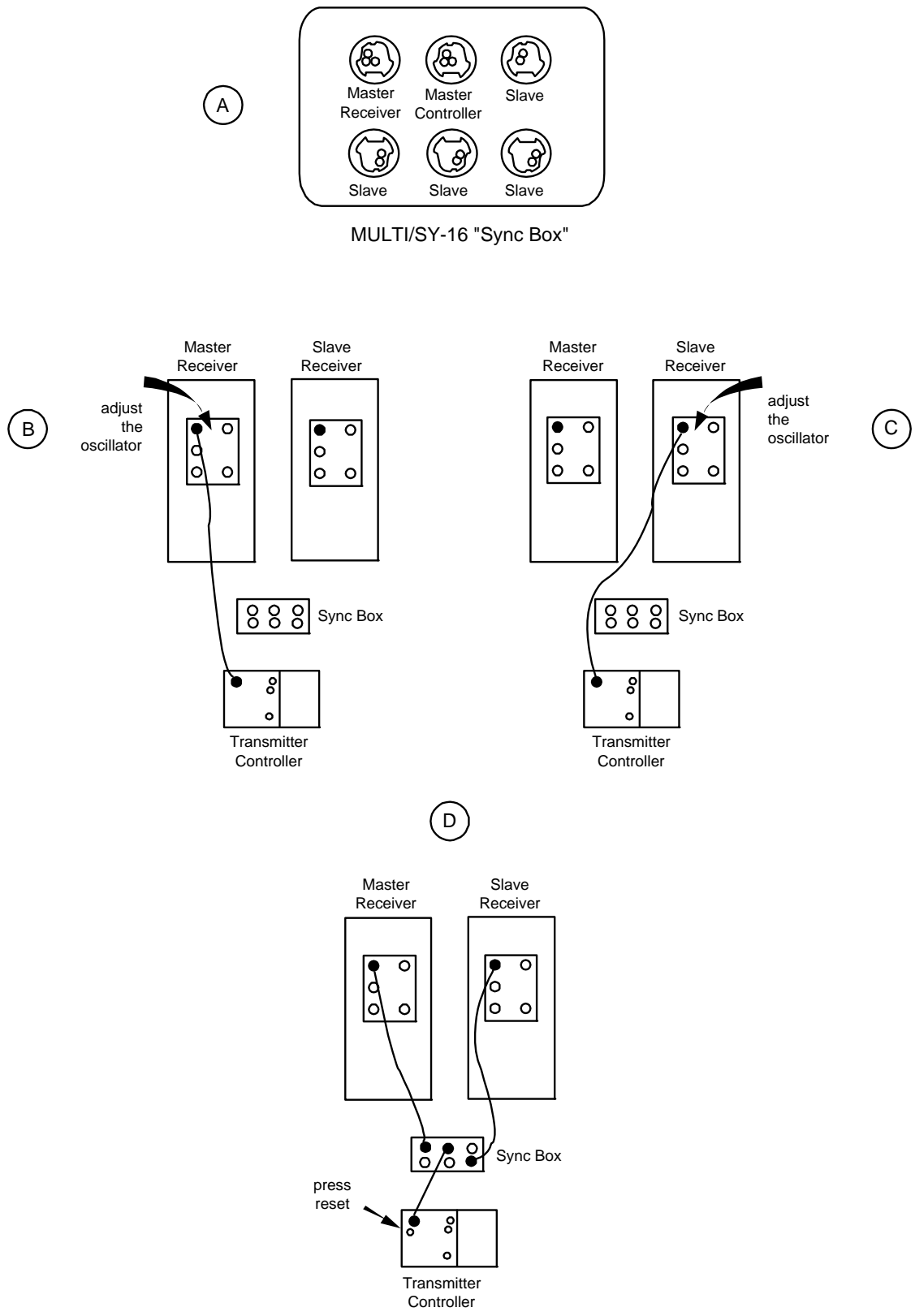

Figure 6.5 - Synchronizing a multiple-receiver system with the older MULTI/SY-16 Synchronization Box.

SYNCHRONIZING MULTIPLE RECEIVERS

With the MULTI/SY-16 Sync. Box:

Two or more receivers can be synchronized to a single XMT-32 with the MULTI/SY-16 Sync Box using the following procedure:

1. Obtain a MULTI/SY-16 Sync Box (Figure 6.5(a)) and extra synchronization cables (one per receiver) from Zonge. Designate one receiver as master and the rest as slave receivers. It doesn't matter which one is master or slave.
2. Connect a synchronization cable between the Transmitter I/O port of the master GDP-32 receiver and the transmitter controller's I/O port, as shown in Figure 6.5(b).
3. Adjust the oscillator frequency using the “Synchronizing the Transmitter and Receiver” routine on the master receiver, but do not push **RESET** on the transmitter controller.
4. Remove the synchronization cable from the master receiver and attach to the slave receiver. Refer to Figure 6.5.
5. Adjust the oscillator on the slave receiver, but do not push **RESET**. Continue this process until all receivers are adjusted to the same frequency as the XMT-32.
6. Make attachments as shown in Figure 6.5(d), being careful to connect the receivers and transmitter controller to the proper ports on the Sync Box.
7. Press **RESET**.
8. If the receivers and transmitter controller are connected correctly, the needles on the receivers' meters deflect to the right as long as the **RESET** button is depressed. The meters will begin to move in synchronization when the **RESET** button is released.
9. Disconnect the synchronization cables.
10. Verify the synchronization operation by measuring the phase difference between the external calibration signal on a particular receiver and the corresponding signal generated by the XMT-32. (See Synchronizing the Transmitter and Receiver.)

NOTE: Up to five receivers can be synchronized to one XMT when using a MULTI_SY-16 Sync Box. Additional Sync Boxes can be linked for synchronizing an unlimited number of receivers.

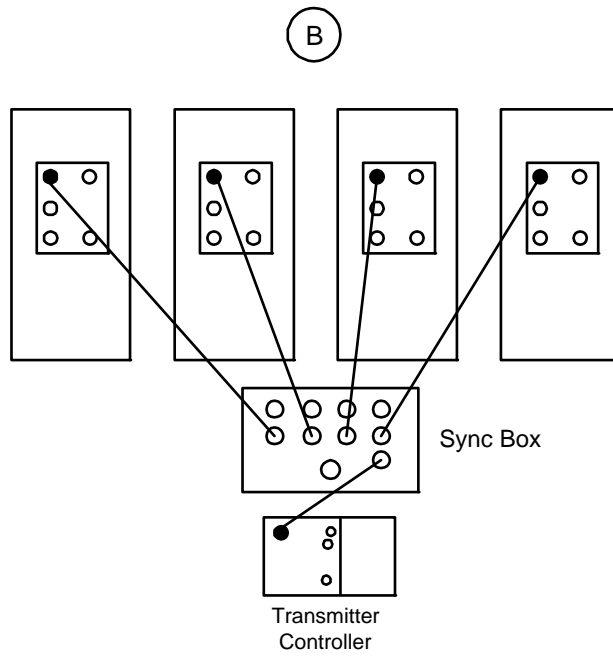
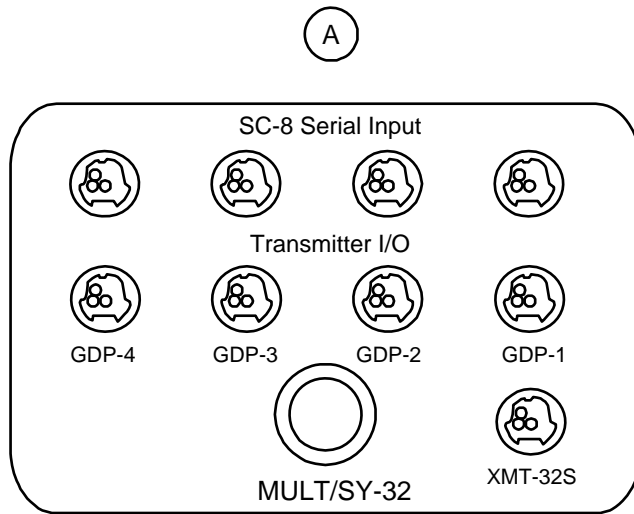

Figure 6.6 - Synchronizing a multiple-receiver system with MULT/SY-32 Synchronization Box

With the MULT/SY-32 Sync. Box:

Up to four GDP-32 receivers can be synchronized to a single XMT-32 with the MULT/SY-32 Sync Box using the following procedure:

1. Connect all GDP-32s to be synchronized to the Transmitter I/O port on the MULT/SY-32 Sync Box (Figure 6.6(a)), as shown in Figure 6.6(b) using synchronization cables.
2. Connect the XMT-32 to the XMT-32/S port on the MULT/SY-32 Sync Box using a synchronization cable.
3. Connect the XMT Cal Output to all GDP-32s:
Red to Red, Ch 2 on GDP-32s
Blk to Blk, Ch 2 on GDP-32s
(Connect all GDP-32s in tandem to XMT.)
4. Using the selector switch on the MULT/SY-32 Sync Box, adjust the oscillator on each GDP-32 until the needle on the XMT comes to rest.

*CAUTION: DO NOT PRESS **RESET** UNTIL ALL GDP-32S ARE ADJUSTED!*

5. Once all receivers have been adjusted, Press **RESET**.
6. If the receivers and transmitter controller are connected correctly, the needles on the receivers' meters deflect to the right as long as the **RESET** button is depressed. The meters will begin to move in synchronization when the **RESET** button is released.
7. Disconnect the synchronization cables.
8. Verify the synchronization operation by measuring the phase difference between the external calibration signal on a particular receiver and the corresponding signal generated by the XMT-32. (See SYNCHRONIZING THE TRANSMITTER AND RECEIVER)

SYNCHRONIZING AN ADDITIONAL XMT

If a spare transmitter controller is available, it can be synchronized along with the rest of the equipment.

1. Adjust all receivers individually, using the master transmitter controller as shown in Figure 6.5 (b) and (c).
2. Connect a cable between the master receiver's Transmitter I/O port and the slave transmitter controller's I/O port.
3. Adjust the slave controller using the OSC TRIM pot on the controller. DO NOT adjust the receiver again, since it has already been trimmed to the master controller.
4. Set up as in Figure 6.5(d), with an additional cable between the slave controller's I/O port and any slave port on the Sync Box.
5. Press **RESET** on the slave controller and keep it depressed while you press and release **RESET** on the master transmitter controller. (**RESET** on the slave controller may be released any time after releasing **RESET** on the master controller.)

Check the synchronization

To check the synchronization of the two transmitter controllers and one GDP receiver:

1. Enable three channels on the GDP.
2. Connect the calibration output of one controller to channel 2 and the other controller to channel 3, with channel 1 connected to the GDP calibration output as shown in Figure 6.5(d).

NOTE: The timing systems of the GDP-16/XMT-16 and the GDP-32/XMT-32 are identical. Field operations may be conducted using receivers and/or transmitter controllers from the different families provided they are equipped with matching crystals.

Most GDP-16's were originally manufactured using 5.0 MHz crystals. However, late in the GDP-16 product cycle, the 4.980736 MHz crystal frequency was adopted because it provided superior noise rejection at powerline frequencies. As a consequence, there are a few GDP-16's and XMT-16's that were originally manufactured with 4.980736 MHz crystals. Many others have been converted to the new frequency at the customer's request. Before mixing components from the two families, it is important to ascertain their crystal frequencies.

Utilities Option 7 Time Schedule Operations

(GDP-32 Manual, Section 5.1)

The Time Schedule Operations enable the GDP-32 and the XMT Frequency Controller to coordinate frequency changes when personal communication is not possible.

The Time Schedule Operations program is loaded at the beginning of the day during synchronization. This function is loaded from a separate portable computer in the field. It is used with the CSAMT, AMT and MT survey programs. See GDP-32 Manual, Sections 11 and 13 for more information.

XMT-32S TIME SCHEDULE *(Bill Graves)*

Equipment Needed

XMT-32

Computer with program: XMT32_TS.EXE

XMT-32 serial cable: XMT-32-SER

Procedure

1. Connect the cable from the XMT-32 to a serial port on the computer.
2. Set the switch on the XMT-32 to "TIME SERIES".
3. Run the program: XMT-32_TS <com port number>
4. Enter the frequency and the duration of each frequency, going from left to right across the table. Use PageUp and PageDown to change values.
5. Enter the start time of the time schedule.
6. When all information is correct, press F1 to send it to the XMT-32. The time on the XMT-32 will be updated to the computer's time and the time schedule will start at the Start Time.

NOTE: It is critical that the time schedule entered into the XMT-32 match the time schedule entered into the GDP. Also, make sure that the DUTY CYCLE switch on the XMT-32 is set correctly.

MECHANICAL ADJUSTMENT OF CRYSTALS

(GDP-32 Manual, Section 17.6)

There is rarely a need to mechanically adjust Crystal Oscillators. Always attempt to adjust Crystal Oscillators electronically first (*GDP-32 Manual, Section 6.2*). If mechanical adjustment is necessary, begin with adjusting the crystal on the XMT.

NOTE: It is always best to contact a Zonge engineer before attempting to perform mechanical adjustments.

Mechanical adjustment of the XMT-32 crystal

After both the receiver and transmitter controller have had power applied for at least 60 minutes, the following procedure can be used to adjust the mechanical trim on the crystals:

1. Set the 20-turn crystal adjust trim pot on the XMT to its mid point (turn the slotted screw 20 complete turns in one direction, then turn the screw 10 complete turns in the opposite direction). This provides for the maximum electrical adjustment range after the mechanical adjustment is made.
2. Turn the power switch on the XMT to OFF.
3. Loosen the 4 hand screws on the right side of the front panel and remove the battery.
4. Remove the 6 screws holding down the left front panel and carefully lift it and the attached boards out of the case.
5. Locate the crystal and the mechanical adjustment access hole cover.
6. Using a small flat-bladed screwdriver, carefully remove the adjustment hole screw located in the middle of the base of the crystal (located next to the coaxial output connector).
7. Attach the battery and turn the Power switch to the ON position. Wait at least 15 minutes for the crystal to warm up again.
8. Connect the synchronization cable between the GDP-32 and the XMT-32.
9. Set the BATT/PHASE switch on the XMT-32 to PHASE, and observe the motion in the meter due to the frequency differences between the crystals.
10. Use the plastic trim tool supplied with the GDP-32 to adjust the mechanical trim pot inside the crystal can. Very carefully rotate the pot about 1/4 turn in one direction and then the other to determine which direction it should be turned to bring the two crystals into synchronization.
11. Adjust the mechanical trim to stop the motion in the phase meter. This should never take more than 1/2 turn in either direction. If more rotation is needed, it could indicate that you have a faulty crystal in either the GDP-32 or the XMT-32.

12. Wait for about one minute to determine that the adjustment is stable. If movement in the phase meter resumes, very carefully adjust the mechanical trim to stop the motion.
13. TURN THE POWER SWITCH TO OFF, replace the screw covering the adjustment hole, and put the XMT-32 back together again.
14. Turn the power switch to ON and wait for 10 minutes before attempting to synchronize the two units again.

Mechanical adjustment of the small case GDP-32 crystal

After both the receiver and transmitter controller have had power applied for at least 60 minutes, the following procedure can be used to adjust the mechanical trim on the crystals:

1. Set the 20-turn crystal adjust trim pot on the XMT to its mid point. This provides for the maximum electrical adjustment range after the mechanical adjustment is made.
2. Set the electrical trim in the GDP to its midpoint. To do this, first get into the utilities menu and select **4) Synchronize to XMT**. Push CONTINUE twice to get to the "Adjust crystal" menu. Hold the SELECT DOWN key down until the beeps change from a slow to a high repetition rate. This puts you on the outside range of the electronic adjustment. Now press the SELECT UP key repetitively for 35 counts (beeps). This will put you in the middle of the adjustment range.
3. Press ESCAPE to exit the utility program and turn off the receiver in the proper manner. Cycle the POWER ON/OFF button on the Control I/O panel to OFF. The red crystal light will be off.
4. Remove the 12 screws holding down the Front Panel.
5. On the front panel assembly, very carefully disconnect the wide blue ribbon cable and the multi-colored cable, both of which go to the card cage motherboard. Also, disconnect the single, black ground wire at the single wire Molex connector.
6. Fold the front panel assembly over toward the left without disconnecting any more cables. Make sure you have something for the front panel to rest upon on the left-hand side of the receiver (a stack of books or something similar).
7. The crystal is located to the left of the card cage and along the side of the battery pack or on top of the battery pack.
8. Use a flat-bladed screwdriver to carefully remove the adjustment hole screw located in the middle of the base of the crystal (next to the coaxial output connector).
9. Cycle the POWER ON/OFF button to ON. Wait at least 15 minutes for the crystal to warm up again.
10. Connect the synchronization cable between the GDP-32 and the XMT-32.

11. Set the BATT/PHASE switch on the XMT-32 to PHASE, and observe the motion in the meter due to the frequency differences between the crystals.
12. Use the plastic trim tool supplied with the GDP-32 to adjust the mechanical trim pot inside the crystal can. Very carefully rotate the pot about 1/4 turn in one direction and then the other to determine which direction it should be turned to bring the two crystals into synchronization.
13. Adjust the mechanical trim to stop the motion in the phase meter. This should normally take less than 1/2 turn in either direction. If more rotation is needed, it could indicate that you have a faulty crystal in either the GDP-32 or the XMT-32.
14. Wait for about one minute to determine that the adjustment is stable. If movement in the phase meter resumes, very carefully adjust the mechanical trim to stop the motion.
15. CYCLE THE POWER ON/OFF BUTTON TO OFF, replace the screw covering the adjustment hole, and put the receiver back together again.
16. Turn on the power and wait for 10 minutes before attempting to fine-tune the crystal frequency. Synchronize the two units by executing the **Synchronize to XMT** option in the **Diagnostic** program of the GDP-32 (Press 2 in the main menu).

The above procedure should permit accurate synchronization once again.

Mechanical adjustment of the large case GDP-32 crystal

After both the receiver and transmitter controller have had power applied for at least 60 minutes, the procedure above can be used to adjust the mechanical trim. The crystal in the large case configuration is mounted on the calibration and timing board. The board is located in the left-most slot of the analog card cage, accessible by opening the battery compartment (bottom lid) of the GDP-32. Follow the same procedure as indicated for the GDP-32T.