

ZONGE GGT-3
GEOPHYSICAL TRANSMITTER
MAINTENANCE and REPAIR MANUAL

Zonge International
3322 East Fort Lowell Road, Tucson AZ 85716, USA
Tel: 520-327-5501 Fax: 520-325-1588 Email: Zonge@Zonge.com

Blank Page

Table of Contents

| | | |
|----------|--|-----------|
| 1 | INTRODUCTION..... | 5 |
| 2 | GGT-3 SPECIFICATIONS | 6 |
| 2.1 | Electrical | 6 |
| 2.2 | Mechanical..... | 6 |
| 2.3 | Electronics | 7 |
| 2.4 | Front Panel Controls | 7 |
| 2.5 | Controls..... | 7 |
| 2.6 | External Control | 8 |
| 3 | OPERATING INSTRUCTIONS | 9 |
| 3.1 | First Time Operation | 9 |
| 3.2 | Motor-Generator Hook-up Procedure (BMG-Series)..... | 10 |
| 3.3 | Description of Controls..... | 12 |
| 4 | THEORY OF OPERATION | 15 |
| 4.1 | Board 204 | 15 |
| 4.2 | Board 93 | 15 |
| 4.3 | Board 131 | 16 |
| 5 | TROUBLE-SHOOTING PROCEDURES | 20 |
| 5.1 | High Voltage Areas | 20 |
| 5.2 | Disassembly..... | 20 |
| 5.3 | Board 204 – Insulated Gate Bipolar Transistor (IGBT) Drive | 21 |
| 5.4 | Board 93 - Output Switch Control | 26 |
| 5.5 | Board 131 - Current Feedback and SCR Drive Signals | 29 |
| 5.6 | Power Supply..... | 34 |
| 5.7 | Loop Switch | 34 |
| 6 | APPENDIX..... | 35 |
| 6.1 | Checking Phase Sequence - Alternator | 35 |

Table of Figures

| | | |
|-------------------|--|------------------|
| <i>Figure 1.</i> | <i>Safe Operating Curves for GGT-3</i> | <i>Fig01.wmf</i> |
| <i>Figure 2.</i> | <i>Output Waveforms</i> | <i>Fig02.wmf</i> |
| <i>Figure 3.</i> | <i>GGT-3 Front Panel</i> | <i>Fig03.wmf</i> |
| <i>Figure 4.</i> | <i>Board 204</i> | <i>Fig04.wmf</i> |
| <i>Figure 5</i> | <i>Board 204</i> | <i>Fig05.wmf</i> |
| <i>Figure 6</i> | <i>IGBT Diode and SCR illustrations</i> | <i>Fig06.wmf</i> |
| <i>Figure 7.</i> | <i>IGBT Drive Waveform (+15V/-10V)</i> | <i>Fig07.wmf</i> |
| <i>Figure 8.</i> | <i>GGT-3. Left Side</i> | <i>Fig08.wmf</i> |
| <i>Figure 9.</i> | <i>GGT-3, Right Side</i> | <i>Fig09.wmf</i> |
| <i>Figure 10.</i> | <i>(reserved)</i> | <i>Fig10.x</i> |
| <i>Figure 11.</i> | <i>GGT-3, Block Diagram</i> | <i>Fig11.wmf</i> |
| <i>Figure 12.</i> | <i>Board 93, Switching Control</i> | <i>Fig12.wmf</i> |
| <i>Figure 13.</i> | <i>Board 131, Phase Control & Protection</i> | <i>Fig13.wmf</i> |
| <i>Figure 14.</i> | <i>SCR Driver Waveform, 38.4 Khz Burst</i> | <i>Fig14.wmf</i> |
| <i>Figure 15.</i> | <i>SCR Firing Sequence</i> | <i>Fig15.wmf</i> |
| <i>Figure 16.</i> | <i>Power Cable, Military Plug, Transmitter end</i> | <i>Fig16.wmf</i> |
| <i>Figure 17.</i> | <i>Power Cable Phase Diagrams</i> | <i>Fig17.wmf</i> |
| <i>Figure 18.</i> | <i>Front Panel Lamp Functions</i> | <i>Fig18.wmf</i> |
| <i>Figure 19.</i> | <i>GGT-3, SCR Wiring Diagram</i> | <i>Fig19.wmf</i> |
| <i>Figure 20.</i> | <i>IGBT Heat Sink Wiring Diagram</i> | <i>Fig20.wmf</i> |
| <i>Addendum.</i> | <i>Power Supply Data Sheet</i> | <i>Pspg.pdf</i> |

1 INTRODUCTION

This manual is intended to provide the information necessary to operate the GGT-3 and keep it in proper operating condition. It also provides the information necessary to repair the most common transmitter problems.

Section 2 deals with the specifications for the GGT-3 and presents the curves for safe areas of operation. These curves should be observed at all times since operation outside these areas causes immediate component damage.

Section 3 deals with the instructions and procedures needed to operate the GGT-3 in the field.

Section 4 covers the theory of operation of the GGT-3 and contains valuable information should troubleshooting become necessary.

Section 5 covers information necessary to troubleshoot the GGT-3 properly in the field. The troubleshooting and repair steps cover those which are possible in the field. The intent of this guide is to provide the operator with a set of explicit instructions for testing the major features of each board so that the operator can determine if repair in the field is possible, if specific boards or modules must be replaced, or if the GGT-3 must be returned to our service center.

NOTE: SPECIFICATIONS ARE SUBJECT TO CHANGE WITHOUT NOTICE.

2 GGT-3 SPECIFICATIONS

2.1 Electrical

Input: 120/208 Volts 3-phase 400-cycle

All input power goes through a 3-phase contactor for power control.

Standby Power: 25 VA

Power connector: MIL SPEC Screw type

GGT-3 Output Table

| <u>ControlRange</u> | <u>Current Settings Frequency Domain</u> |
|---------------------|--|
| 650- 1000V | .2-3.0 amp |
| 400- 750V | .2-4.0 amp |
| 150- 500V | .2-6.0 amp |
| 50- 250V | .2-12.0 amp |
| 25- 125V | .2-15.0 amp |

This chart is for DC to 1 KHz output frequency, using time or frequency domain and pulse EM wave form. Refer to *Figure 1* for safe operating range curves.

2.2 Mechanical

GGT-3

Weight: 70 lb., (32 Kg)

Case: L16 x W10 x H21 inches (40 x 25 x 53 cm)

Case Construction: Aluminum. All high voltage components are physically isolated from the low voltage components and wiring. The heat sink is the chassis and case with an internal fan to circulate the air throughout the transmitter.

2.3 Electronics

Solid state electronics are incorporated for control and protection circuits. There are separate gate drive cards for each output device with protection sensing. All drive modules for the output switch are interchangeable.

Overcurrent sense and shut down is present for each IGBT module. All connections between the high voltage section and control section are isolated by fiber optic links, isolation transformers, and industrial grade isolation amplifiers.

2.4 Front Panel Controls

Meters: Digital LCD and Analog

Input Voltage Meters (Analog): 0 to 150V

Output Voltage (Analog): 0 to 1000 volts

Output Current (Digital): 0 to 19.99 amps

2.5 Controls

POWER ON/OFF, TRANSMIT/RESET. The main AC contactor will open for fault conditions, isolating the equipment in case of an emergency. When going to transmit, the contactor closes, and power will ramp up to preset level.

Voltage taps: 1000, 750, 500, 250 and 125. These are chosen for best efficiency for ground loading. Output current is adjustable from 0.2 to 100 percent of full scale. See Output Table, *Section 2.1*.

Current range is adjusted with a 10-turn potentiometer.

2.6 External Control

Frequency and duty cycle are controlled by an external controller. A 20ma current loop is used to control the logic. It is isolated from the rest of the system by a fiber optic link connecting the input plug to the control board.

The controller manufactured by Zonge is capable of time or frequency domain operation. In time domain, duty cycles of 50% may be selected. In frequency domain, any 16 consecutive, binary-interval frequencies in the range of 1/1024 Hz to 10 kHz may be selected. The controller is isolated from the transmitter by an optical coupler link. Custom controller units that will match the transmitter to most other well-known geophysical systems can be supplied with the transmitter.

3 OPERATING INSTRUCTIONS

3.1 First Time Operation

3.1.1 Inspection

Inspect the transmitter on arrival for any damage that may have occurred during shipment. Remove the transmitter from its case and inspect the printed circuit cards for damage. Check for connectors and cables that may have come loose during shipment. If any damage has occurred, it should be reported to the shipper and to Zonge immediately and corrected before operation is attempted.

3.1.2 Preparatory Set-up

Set the controls as follows:

| | |
|----------------|-----------|
| CONTROL POWER | OFF |
| OUTPUT VOLTAGE | 125 VOLTS |
| CURRENT SET | 0 |

Connect a 100 ohm resistive load (dummy load - Zonge Model #LB2500) to the red and black output jacks on the transmitter.

Connect a 3-phase power source (120/208 volts - 400 Hz) to the transmitter power input. (See *Section 3.2* for operation of the BMG-series motor generators.) The pins on this connector are labeled A, B, C, and D. D is the neutral input. Pins A, B, and C are the A-phase, B-phase, and C-phase respectively. C lags B by 120 degrees, and B lags A by 120 degrees. This is important for proper operation of the GGT-3. If in doubt, refer to the APPENDIX, Checking Phase Sequence - Alternator.

Note: Input voltage for GGT-3 has been optimized for 115/200 v although all of our engine/generator sets are specified as 120/208 v. This has been done to ensure a broader operating range of input voltages for full output.

Connect a battery powered or line isolated oscilloscope to the CAL output jacks

on the transmitter. **CAUTION: FAILURE TO USE AN ISOLATED OSCILLOSCOPE CAN CAUSE A SHOCK HAZARD AND MAY DAMAGE THE OSCILLOSCOPE OR THE OPERATOR.** Set up the oscilloscope as follows:

0.5 mSec/division
0.5 volt/division

Connect a transmitter controller to external control (XMT-32 or GDP-32) and set the frequency to 8 Hz and frequency domain.

Turn on CONTROL POWER. The green power indicator should be on. All lamps should light with the automatic lamp test. Toggle the TRANSMIT/RESET switch to RESET. All indicator lights should be OFF except for END REG and control power. If others are on, check for loose cables. If the cables are not loose, the transmitter has been damaged in shipment and the failure should be reported to Zonge for corrective action. To test for burned out or damaged lights, turn off control power and then back turn on after 10 seconds. This will cause all lamps to turn on.

Replace any burned-out bulbs by unscrewing the lens and placing a new bulb in the socket. All lamps are 5-volt bulbs.

Toggle the TRANSMIT/RESET switch to RESET and then immediately to TRANSMIT (*Section 3.3.1*). Do NOT hold TRANSMIT in the TRANSMIT position. Release the switch immediately after going to TRANSMIT. Adjust the current control knob to 2 amps output current.

The FREQUENCY/TIME DOMAIN switch on the transmitter controller can be toggled between either position. The oscilloscope trace should look as in *Figure 2*. Note: Do not toggle this switch when transmitting, when the DIPOLE/LOOP switch is on LOOP, or the fuse will blow on the loop switch circuitry.

3.2 Motor-Generator Hook-up Procedure (BMG-Series)

Disconnect the MG trailer from the towing vehicle and level the unit as much as

possible to permit normal oil circulation in the motor. Skid-mounted MG sets should be placed on level ground.

- Remove the motor tarp and generator cover.
- Check the oil level with the dipstick. Add oil if necessary.
- Check the belt tension (belts should deflect at least 1 to 2" [2 to 5 cm] at the center of the belt, but should not deflect more than 4" [10 cm]).
- Check all nuts, bolts and wires. Tighten any loose components.

Place the voltage regulator (VR) on the ground, on the generator cover (for electrical protection of the VR). Connect the VR to the alternator using the proper cable. Place the VR out of the way and in the shade if possible. Under the trailer is a good place: it can't be tripped over, it is in the shade and it will be convenient to operate. Make sure the VR is turned off.

Connect the power cable between the VR (applicable to GGT-3 only) and the transmitter. Route the cable on the ground, out of standing water, and out of the way. It is not recommended procedure to leave the cable where it can be tripped over. When tightening the military-style connectors, screw the threaded sleeve until it is tight, then push and wiggle the connector to confirm the sleeve is as tight as possible. Do this with the connector on the GGT- 3 as well as the connector on the MG.

Once the MG has been checked out it may be started. If the motor is cold, pull the choke out a short distance from the control panel. Turn the ON-OFF switch to ON. The electric starter should crank the motor and it should start within 30 seconds. If it doesn't, refer to the manufacturer's literature. Once the motor has started, allow it to idle for about five minutes. Push the choke in after a few seconds, or a little longer if the weather is very cold or damp.

Once the BMG is warmed up, the engine speed can be increased to approximately 4000 RPM by pulling the throttle lever to the right, then the

alternator may be put into use. Refer to the *VR MANUAL* for complete instructions and troubleshooting procedures.

Turn the voltage regulator ON and depress the VR START button MOMENTARILY until the alternator is working. Holding the button down too long can damage the alternator, the alternator cooling fans, the GGT cooling fans, or VR circuitry. If it doesn't start, check the internal battery pack.

Confirm that the cooling fan on the alternator is running. Operation under heavy load without the cooling fan will rapidly damage the alternator by overheating it.

Adjust the engine speed to produce an AC frequency between 400 and 425 Hz. Adjust the VOLTAGE ADJUST for 115 volts. See the *VOLTAGE REGULATOR MANUAL* for complete instructions.

3.3 Description of Controls

Refer to *Figure 3* for the following description of controls.

3.3.1 RESET/TRANSMIT switch.

The RESET/TRANSMIT switch resets all of the internal circuitry in the GGT-3. The GGT-3 cannot transmit until a valid RESET is given. After RESET is activated the operator has a two second time-out period during which a valid TRANSMIT can be given. If TRANSMIT is not activated during this two second period another RESET must be given. This insures proper sequencing of the internal circuitry.

3.3.2 TRANSMIT light.

The TRANSMIT light indicates that the GGT-3 is transmitting and high voltage is present on the output. The light will go off when a fault or reset opens the safety power contactor. The output polarity lamps will alternately flash.

3.3.3 SUPPLY OVERVOLTAGE light.

The SUPPLY OVERVOLTAGE light indicates that the voltage level on the supply to the output switch has exceeded the safe operating level of 1000 volts. This can be caused by driving a large capacitive load or by running with an input voltage from the alternator of more than 115 volts, while using the 1000 volt tap on the TRANSFORMER OUTPUT VOLTAGE switch.

3.3.4 OUTPUT OVERVOLTAGE light.

The OUTPUT OVERVOLTAGE light indicates that the voltage level on the output has exceeded 1000 volts. This can indicate that a largely inductive load is present on the output.

3.3.5 Status lights

The INPUT VOLTAGE light indicates that the voltage level from the alternator exceeded 130 volts or was less than 95 volts and must be adjusted into the proper range, preferably 115 volts.

The OPEN OUTPUT light indicates that the output circuit is open and the transmitter is trying to transmit into an infinite load. NOTE: do not set the current pot to zero, as the GGT-3 will not transmit.

3.3.6 OVERCURRENT lights.

The INPUT OVERCURRENT light indicates that too much current has been requested from the supply generator. The detection level is 13 amps and is set at the factory.

The OUTPUT OVERCURRENT light indicates an overcurrent condition in one of the output IGBT modules. If this lamp will not reset it indicates that an IGBT module has been damaged. Refer to the troubleshooting section. The detection level is set at desaturation of the IGBT's. It is not adjustable.

3.3.7 END REG. light.

The END REG. light indicates that the transmitter is not able to supply the amount of current desired. Either the current must be lowered or the TRANSFORMER OUTPUT VOLTAGE tap switch must be set to a higher voltage. It will also turn on when the output current is set too low, showing an unregulated condition.

3.3.8 POLARITY lights

These two lights indicate the polarity of the output waveform. They will alternate or turn OFF in Time Domain to indicate the state of the transmitter output.

3.3.9 OVERTEMP light

This light indicates that the internal temperature of the transmitter has exceeded 150°F (65°C). It will also reset the transmitter and not allow any output until the temperature drops below 130°F (54°C).

3.3.10 FAN light

This light indicates that the temperature is above 90°F (32°C). and that the fan is now ON and circulating air. If the temperature is high and conditions permit, open the side vents. NOT USED IN CURRENT MODELS

3.3.11 TRANSFORMER OUTPUT VOLTAGE tap switch.

The TRANSFORMER OUTPUT VOLTAGE tap switch selects the output voltage range of the transformer and sets operation over the range described in the Output Table in *Section 2.1*.

3.3.12 DIPOLE / LOOP – 2AMP / 20AMP switch

This switch turns the loop damping circuits ON and OFF. It should be in LOOP position only for TEM operation. Do not switch while the GGT-3 is transmitting. For very low current, high resistance operation, go to the 2 AMP range.

4 THEORY OF OPERATION

4.1 Board 204

Board 204 (*Figure 4*) accepts drive control signals from Board 93 and uses these to control the turn-on and turn-off of the IGBTs. Each board has its own transformer and power supply. This is because the ground on Board 204 is connected to the emitter of the IGBT and needs to be isolated during operation.

This board has a dual supply that generates +15, -10 volts for the IGBT driver chip, M57959L (*Figure 7*), that provides drive and protection to the IGBT module. It generates a fault condition if the IGBT comes out of saturation during a current fault. There are a pair of fiber optic devices, a transmitter and a receiver, to control the drive module switching and fault generation. These provide for high voltage isolation between the four drive boards. All four Board 204's must be isolated from each other for proper operation of the transmitter.

4.2 Board 93

There is a test switch located on this board (*Figure 12*) for ease of troubleshooting. This switch must be in the RUN position for normal operation. When in a test position, this switch provides either a 4 Hz or 1024 Hz drive signal. *Note: older boards are marked 1 Hz and 256 Hz.*

When RESET is activated, one of the 4538 ICs generates a two microsecond reset pulse that goes to all the protection latches. RESET also goes to a second 4538 that is used as a two second timer. The purpose of this circuitry is to insure that the transmitter cannot be made to transmit before a valid RESET is generated. After RESET is activated the operator has two seconds to activate TRANSMIT. If TRANSMIT is not activated within two seconds another RESET will have to be given to initiate transmitting.

When TRANSMIT is activated during the two second time-out, one half of a 74C74 latches the contactor relay driver (DS3631 or 75451). A fault condition will reset the contactor latch and remove power from the transformer and drive to the IGBTs.

The deadtime circuitry is set for an two microsecond deadtime which is used to gate-out overcurrent detection during switching. It is generated by a 4520, 74C74, and a 1 MHz oscillator. One half of the 4520 is held in a reset state while the other half is counting. When reset on the 4520 is removed it counts two oscillator cycles before triggering one half of the 74C74, and causes a drive signal to be generated. Loss of the oscillator prevents the drive signal from being generated.

Overcurrent is latched on this board. The fiber optic signal for overcurrent is active-low or OFF. This insures that the loss of a cable will protect the drive cards and prevent drive signals from being generated. Four latched indicators are included on board to help determine the exact source of the overcurrent situation. These correspond to the IGBT modules on the heat sink.

OVERVOLTAGE is latched on this board and the signal is active - high or ON.

4.3 Board 131

The purpose of this board (*Figure 13*) is to regulate the output current of the transmitter. This board provides the drive to the controlled bridge rectifier, feedback control of the bridge, plus inhibit and protection functions during faults. Its main function is to maintain a constant current at the output of the transmitter for varying loads.

Due to the harmonic noise generated by the phase control of the output voltage, the primary waveform from the alternator is distorted from a pure sine wave. In order to minimize the noise on the reference signal, an active filter is used to remove the higher harmonics. The active filter is set for a phase shift of 60

degrees at 400 Hz. This is compensated for in the control circuitry. The filter provides the reference waveform for all of the control circuits. The output of the filter is sent to the phase lock loop.

The phase lock loop circuit (4046) is used to multiply the 400 Hz signal to a higher value that is then divided by two divider chains, one divides by 768 and the other divides by 128. These give outputs of 400 Hz and 2400 Hz respectively from a master frequency of 307.2 kHz. The 2400 Hz signal is used by the ring counter to clock the data which comes from the main comparator. This provides the equidistant pulses used to fire the controlled bridge SCRs. The 400 Hz output of the other divider chain is fed back to the 4046 phase lock loop. It is this phase reference which is compared with the input waveform. This keeps the multiplied signal phase locked to the input frequency. Due to the large capture ratio of the system, the phase locked loop can remain in lock over a large range of frequencies. After power up on the system, it may take a second or so for the phase lock loop to lock in. After it locks in, it should remain so for all conditions except a complete loss of power.

The main comparator provides updated information on the output current to the firing circuits. It provides the reset pulses for the ring counter. The comparator switches its output in reference to the DC level of the control voltage as compared to the full wave rectified sine wave. The switching point provides the timing for the firing angle of the SCRs. Maximum firing angle is reached when the control voltage is equal to the peak of the reference sine wave, while the converse is true when the control voltage is at zero. During normal regulation, the control voltage will increase and decrease as needed to maintain a constant output current.

The next section covers the control and protection circuitry of Board 131. There are two divisions to this section, one covers the current feedback loop and the other provides protection from faults in the system.

4.3.1 Current Regulation

This is composed of the following sections: current setpoint, slow turn-on, isolated current sensing, and integration of the current setpoint with current feedback.

4.3.2 Current Setpoint

Current control is accomplished by sensing a control voltage that is buffered by an amplifier controlling the offset of the integrator's negative input. This voltage sets the point at which the integrator output is equal to the voltage required to maintain a steady state current in the feedback loop.

4.3.3 Current Feedback

The transmitted current is sensed across a 0.1 ohm resistor on the 20 amp scale, or a 1.0 ohm resistor on the 2 amp scale, and then sent through a true RMS (Root Mean Square) device (AD536), a sample-hold device and an isolation amplifier. This provides a DC representation of the output with noise and ripple being averaged out. The output of the isolation amplifier is sent to both the integrator and the digital voltage meter through buffer amplifiers.

4.3.4 Transmit, Soft Turn-on

Two other devices tie onto the positive integrator summing junction. These are used in transmitter turn-on and fault control. Soft turn-on is provided by the 74C908. It does this by holding the integrator in an OFF condition until turn-on. Due to the integration time constant, power is applied at a controlled rate. Also, the 74C908 forces the positive input of the integrator to be high in a fault or rest condition.

4.3.5 Fault Detection

The board can sense various out-of-range levels and act accordingly. There are provisions for alternator undervoltage and overvoltage, end of regulation, open

circuit, and input overcurrent.

Alternator under/overvoltage is sensed by the true RMS converter and scaled to be proportional to the input voltage. If it exceeds the preset value, the alternator overvoltage lamp will light and the board will shut down until the voltage reaches a safe value. This is not a latched condition.

End of regulation also uses the alternator voltage and senses when there is not enough voltage to maintain regulation by comparing the alternator voltage to the control voltage. A lamp will light for this condition but no shutdown takes place. This is accomplished by sensing the input supply current through a current transformer, converting this to the RMS value of the input current, and then applying the DC signal to a comparator that is set to trip when the current exceeds 10.2 amps on supply A-phase. This resets the transmitter switch, shutting off the transmitter.

Open Circuit detection also uses this circuitry to detect when the transmitter should be transmitting but no current is being output. Both circuits latch and indicate their condition on front panel lights.

4.3.6 Board 99 - Output Pulse Amplifiers

Board 99 (*Figure 14*) contains the pulse amplifiers and transformers. As long as inhibit is high, the gate drive will output to the drive amplifiers with the modulation signal impressed on it. This signal drives the 2N5335 transistors that drive the pulse transformers. The pulse transformers drive the SCRs and provide isolation between the SCRs and the control board. By using high frequency modulation, an efficient transformer can be used and a lower average current in the pulse transistors is maintained.

5 TROUBLE-SHOOTING PROCEDURES

5.1 High Voltage Areas

Dangerous voltages are present throughout the transmitter. The following is a list of most but not all of the areas where caution should be exercised.

- 3-phase 115 VAC input at the contactor, line fuses, power supply, Board 131, high-voltage transformer, and IGBT drive transformers.
- All heat sinks, that can vary from ground potential to **1000 volts**.
- All boards numbered 204. These float along with the transmitter output and can have **1000 volts** at whatever frequency is being transmitted.
- The voltage-tap switch, phase-control SCRs, filter choke, supply capacitors, protection choke, and protection diode.
- The metal chassis is connected to the AC generator neutral line and under normal operating conditions should not carry high voltage. However, for safety, it is normal to ground the transmitter chassis to a stake well away from any transmitter electrodes.
- All four output terminals are naturally dangerous at all times. When the transmitter is turned off, it takes approximately five seconds for the bleeder resistor to discharge the capacitor completely. It is good practice to touch only one output terminal at a time while keeping your other hand in your back pocket, even when the transmitter is turned off.

5.2 Disassembly

The GGT-3 can be removed from its case by removing the 12 screws along the outer edge of the panel which hold it in place. The unit must be removed to gain access to the component modules on which the IGBTs and SCR thyristors are mounted. Remove the plastic guard panels to gain access to the IGBTs on the right and SCRs on the left. Caution should be exercised when removing or

installing the panel in the case as all components are mounted to the front panel. The GGT-3 should never be operated at frequencies above 256 Hz for any length of time when it is out of the case, because proper cooling will not occur.

5.3 Board 204 – Insulated Gate Bipolar Transistor (IGBT) Drive

This board (*Figure 4*) can be tested by connecting a 115/200 VAC-400 Hz motor generator to the transmitter input military connector. Pin A is the A-phase input and provides power for the internal power supplies on these boards. Pin D is the transmitter neutral. Disconnect the external control source as the internal timing is used for most of the tests on this board. Disconnect the contactor relay by disconnecting the molex plug at Board 93.

NOTE: IT IS VERY IMPORTANT THAT THE CONTACTOR BE DISCONNECTED SO THAT HIGH VOLTAGE WILL NOT BE PRESENT ON THE IGBT MODULE DURING TESTING.

Follow the procedure below to determine if the fault lies with this board or with some other part in the transmitter.

NOTE: ALL RESISTANCE MEASUREMENTS MUST BE MADE WITH TRANSMITTER OFF

- 5.3.1 Verify that Board 93 is working since its proper operation is essential to proper operation of these IGBT drive boards (*Section 5.4*).
- 5.3.2 A fault light that cannot be RESET is a good indication of a IGBT or Board 204 failure. Disconnect the molex connector to the IGBT module suspected to be failing and then follow the procedure below, using a Fluke or similar digital voltmeter. The "from" point uses the ground lead on the Fluke and the "to" point uses the positive lead of the Fluke. All resistance measurements are made with the transmitter turned off. See *Figure 5* to determine where to place probes.

5.3.3 Measure the resistance from emitter to collector of the IGBT (*Figure 5*). The test point is the disconnected molex connector. This reading should be approximately 500 ohms, with a high value diode function meter. Using other meters with low ohms the value may be 30k ohms or 0.35 volts in diode mode. If not, go to *Section 5.3.9*.

5.3.4 Measure the resistance from collector to emitter. This reading should be infinite. If not, go to *Section 5.3.9*.

NOTE: THE FOLLOWING SHOULD BE DONE ONLY IN A NON-STATIC ENVIRONMENT

--- --- --- --- GATES ARE SENSITIVE TO STATIC ELECTRICITY --- --- --- ---

5.3.5 Measure the resistance from gate to collector and from gate to emitter. The gate test point is the molex connector. These readings should be infinite. If not, go to *Section 5.3.9*.

5.3.6 Measure the resistance from collector to gate. This reading should be infinite. If this reading indicates a short, or other resistance, go to *Section 5.3.9*.

5.3.7 Measure the resistance from emitter to gate. This reading should be infinite, If this reading indicates a short, or other resistance, go to *Section 5.3.9*.

5.3.8 If the IGBT has tested okay, go to *Section 5.3.11* to test Board 204.

5.3.9 Replace the IGBT. Disconnect the gate leads at Board 204 by disconnecting the molex connector (*Figure 5*). Remove the two screws in the base of the IGBT and remove it from the heat sink and reverse this process to install the replacement. Avoid excessive torque on the two screws in the base of the IGBT to prevent stripping the holes. The IGBT module is equivalent of two IGBTs and two diodes. Be very careful to connect gate leads to proper connections on the module.

- 5.3.10 Whenever a IGBT fails it is possible that another one has also failed. Check the other IGBT's using the previous procedure. Next, it is essential that the quenching diode, DD31S-1400, be tested around the protection inductor on the heat sink module. If this diode has shorted, then the overcurrent protection will not work and more IGBT's will be lost if another short occurs. If this diode has opened, then the output will be unstable and will cause either OVERVOLTAGE indications or IGBT failure. Test this diode by removing its cathode lead and measuring it with a Fluke or similar digital volt meter on the lowest diode range (2k). Anode to cathode resistance should be infinite. Cathode to anode should be in the range of 500 - 800 ohms. If the diode is bad replace it. Test all the quenching diodes using the same procedure.
- 5.3.11 Turn on the transmitter. Reset the transmit switch and make sure all lamps are out. Check for -10 volts between gate lead and emitter on Board 204s (*Figure 7*). If present, go to *Section 5.3.13*, otherwise continue with *Section 5.3.12*.
- 5.3.12 Check the circuit breaker. If it has tripped, reset it and recheck for 120 VAC input at each module. If 120 VAC is still not present check for wiring problems, or problems with the power source. Correct the problem and go to *Section 5.3.13*. If the modules continue to trip the circuit breaker, determine which module is responsible and replace it.
- 5.3.13 Check the +15 volt supply at the output of the 340-15. This should be within 1/2 volt of 15 volts. If this supply is within this limit, go to *Section 5.3.16*.
- 5.3.14 Check the input to the positive regulator (340-15) from the bridge rectifier. This should be approximately +20 volts but will vary according to the input source voltage. If the input is not +20 volts, check D2, C4 and the output of the transformer. Correct the problem and go to *Section 5.3.13*.
- 5.3.15 If the input to the regulator is correct but the output is not, check the drive device for shorts (57959) or the five volt regulator. Correct the problem and go to

Section 5.3.13.

5.3.16 Check the -10 volt supply at the output of the negative regulator (337). This should be within 1/2 volt of 10 volts. If this supply is within this limit, go to Section 5.3.19.

5.3.17 Check the input to the negative regulator (337) from the bridge rectifier. This should be approximately -20 volts, but will vary according to the input source voltage. If the input is not -20 volts, check D5, C8 and the output of the transformer. Correct the problem and go to Section 5.3.16.

5.3.18 If the input to the regulator is correct but the output is not, then check the regulator, and the IC (57959) for a failure. Correct the problem and go to Section 5.3.16.

5.3.19 Check the 5 volt regulator (78L05). Use the ground reference. If the regulator is putting out 5 volts +/- 0.5 volts, go to Section 5.3.20. If the regulator is failing, replace it and recheck the output. If it still appears to be failing, then the optical receiver that it is supplying it is bad and must be replaced. Correct the problem and continue.

5.3.20 Plug in all of the cables to the IGBT drive modules and set the test switch on Board 93 for a 1024 Hz test signal. Then apply power to the unit and activate the RESET switch on the transmitter. All of the fault lights should be out. If not, go to Section 5.3.39 before proceeding any further. The fault light will indicate a failing module, but others may also be failing and can be checked by performing this same procedure starting at Section 5.3.2.

5.3.21 Connect the molex connector on all IGBT modules. Attach an oscilloscope to the emitter (ground) lead of Board 204 and the gate output. The output observed on the scope should be a 1024 Hz square wave of at least +15/-10 volts (Figure 7). This should be observed on all four boards. When the square wave is not present or of only one polarity, the board is not driving properly. Go to Section

- 5.3.23 in this case. When the proper square wave is observed, connect a 100 ohm 2 watt resistor between gate and emitter (ground). The square wave will diminish in amplitude but should still be present. If the square wave becomes unipolar when the resistor is added, go to Section 5.3.23.
- 5.3.22 Reconnect the leads between Board 204 and the IGBT heat sink modules. The output should look like *Figure 7* on all modules. If not, recheck *Section 5.3.21* and if the problem is still present go back to *Section 5.3.2* and recheck the IGBT. If the output agrees with *Figure 7*, Board 204 is working properly. Turn the transmitter OFF and check diode D4 using a Fluke meter on the diode range. Replace the diode if it is open or shorted. It is recommended to test D4 in this manner because testing it while transmitting without the proper high voltage probe can be hazardous to the operator.
- 5.3.23 Recheck the power supplies (+15,-10,+ 5 volts) using *Sections 5.3.13* to *5.3.19*, and correct any power supply problems. Set the test switch on Board 93 to 1024 Hz.
- 5.3.24 Connect the scope ground lead to the emitter on Board.204. Connect the scope probe to cathode of 57959 IC. A 1024 Hz signal between +5 volts and not quite ground should be visible. If present, go to *Section 5.3.26*. If this is not present, check the fiber optic DRIVE cable from Board 93. The light should be red. Move the test switch on Board 93 to the 1 Hz position. Now the drive signal should alternate on and off at a 1 Hz rate. If there is no drive signal and no fault lights are on, repair Board 93. Board 93 will not produce drive signals when faults are indicated. If fault lights are ON and RESET does not clear the fault, go to the troubleshooting procedure for Board 93. If the fiber optic drive is working and the signal at the output of fiber optic is incorrect as tested above, continue on.
- 5.3.25 NOTE: The IGBT devices will output an OVERCURRENT fault whenever they are disconnected from Board 204. It is a little more difficult to determine which module is bad. The best method is still to replace any module which seems to

vary in tests from a new one.

5.3.26 Observe the light output of the gray optical transmitter. When the IGBT module is connected to Board 204, the light should be ON, and when disconnected it should be dim, and flashing at a high rate. If it does this, the current sense circuitry is working properly. Go to *Section 5.3.20* and recheck.

5.4 Board 93 - Output Switch Control

This board (*Figure 12*) can be tested by connecting the transmitter to a motor generator. Pin A is the A- phase input and provides power for the internal power supplies for this board and the IGBT driver modules. Pin D is the transmitter neutral and is connected internally to the transmitter chassis. Therefore, an isolation transformer is needed on the oscilloscope. Disconnect the external drive source as the internal timing is used for most of the tests on this board. Disconnect the contactor relay by disconnecting the molex plug by the contactor.

NOTE: IT IS VERY IMPORTANT THAT THE CONTACTOR BE DISCONNECTED SO THAT HIGH VOLTAGE WILL NOT BE PRESENT ON THE OUTPUT DURING TESTING.

Follow the procedure below to determine if the fault lies with this board or with some other part in the transmitter.

NOTE: ALL RESISTANCE MEASUREMENTS SHOULD BE MADE WITH THE TRANSMITTER OFF. DISCONNECT THE CONTACTOR CONTROL WIRE FROM BOARD 93 (YELLOW WIRE WITH SINGLE MOLEX CONNECTOR) WHEN DOING ANY MEASUREMENTS ON THE TRANSMITTER THAT DO NOT REQUIRE OUTPUT. Check SV power to board.

5.4.1 Push "RESET".

5.4.2 If the OVERVOLTAGE lights are still ON, go to *Section 5.4.15*.

5.4.3 If the OVERCURRENT lights are still ON, go to *Section 5.4.17*.

5.4.4 Set the test switch on this board to the 1 Hz position and pull all of the fiber-optic

cables labeled DRIVE (*Figure 12*). These connectors are gray. Observe the lights (LEDs) in the four optical drivers. DRIVE1 and DRIVE2 should be alternating with DRIVE3 and DRIVE4 at 1 Hz. If this is not occurring, go to *Section 5.4.8*.

- 5.4.5 Set the test switch to the RUN position and attach the external controller. Set the frequency to 1 Hz and again observe the output from the four optical drivers. If they do not alternate, go to *Section 5.4.7*.
- 5.4.6 Reinstall the four drive cables: this board has tested okay. Go to *Section 5.4.15*.
- 5.4.7 Check the fiber optic cables from the drive input Board 91 to Board 93 to insure that all cables are installed properly. If this does not correct the problem, pull the TRANSMITTER DRIVE cable from Board 93 and observe the output from the cable. The light should be alternating ON and OFF. If it is not, the external controller may be off or malfunctioning, or the input optical driver may be bad. If the output of the cable is alternating ON and OFF, then either the optical receiver is bad or IC C3 is bad. Correct the problem and go to *Section 5.4.5*.
- 5.4.8 Using an oscilloscope check for a 4 MHz square wave at pin 1 of IC B5. If there is no signal here, check the five volt supply to this board and be sure power is ON. If power is ON and five volts is absent, check the power supply and replace it if necessary. If five volts is present, replace the oscillator and go to *Section 5.4.4*.
- 5.4.9 Check for a 4 Hz drive signal on pins 7 and 15 of IC B5 (4520). If this is not present, make sure that the test switch is in the 1 Hz position. If the 1 Hz drive signal is not present, IC C3 or C4 is bad. Replace the faulty IC, check the drive signal, and go to *Section 5.4.4*.
- 5.4.10 Set the test switch to 1024 Hz. A 1024 Hz square wave should be present at pins 3 and 11 of IC B4. If this square wave is not present, IC B5 is bad and must be replaced. Replace IC B5, check the square wave again, and go to *Section*

5.4.4

- 5.4.11 Check for a 1024 Hz square wave at pins 5 and 9 of IC B3. If this is not present, replace IC B4 and go to Section 5.4.4.
- 5.4.12 Check for a 1024 Hz square wave at the output of IC B3. If this is not present, look at the levels on the following pins. Pins 1, 2, 4, 10, 12, and 13 should all be at five volts. If they are not, check for fault lights being ON, five volt power supply failure, IC C3 failure or Duty Cycle optical receiver failure. Correct the failure and go to Section 5.4.4.
- 5.4.13 Check for a 1024 Hz square wave at pins 3 and 5 of IC B2. If this is not present, either B2 or the optical drivers are bad. Determine which is failing and replace.
- 5.4.14 Check for an active drive signal light at the output of the optical drivers. If present, go to Section 5.4.15. If not, go back to Section 5.4.8 and recheck the signals.
- 5.4.15 Pull all four of the OVERCURRENT cables from the blue optical receivers labeled PROT1, PROT2, PROT3, and PROT4. This should cause the OVERCURRENT fault lights to turn ON. Now reinstall the four OVERCURRENT cables and push the RESET switch and observe the fault lights. If the OVERCURRENT fault lights reset, then go to Section 5.5. If not, then IC D9 or the OVERVOLTAGE optical receiver is bad. Correct this problem and go to Section 5.4.1. If the OVERCURRENT fault lights stay ON, go to Section 5.4.16.
- 5.4.16 The tests indicate that either IC D4 or the RESET switch wiring is bad. Correct the problem with the RESET circuitry and go to Section 5.4.1.
- 5.4.17 Pull the OVERCURRENT fault cable associated with the fault light which cannot be reset. If the end of the cable glows red, go to Section 5.4.19.
- 5.4.18 The IGBT module (Board 204) associated with the unlighted cable is failing or has its cable unplugged. Repair the module or plug in the cable and go to

Section 5.4.1.

5.4.19 Pull the other OVERCURRENT cables. The OVERCURRENT fault lights should turn on. Reinstall the cables and activate the RESET switch. If the OVERCURRENT lights associated with the cables that were pulled do not go OUT, go to Section 5.4.16.

5.4.20 Check the ICs associated with the fault light that cannot be reset, which will be either C7, D7, C6, C8, C9 and the optical receiver associated with the fault light. Repair the problem and go to Section 5.4.1.

5.5 Board 131 - Current Feedback and SCR Drive Signals

This board (*Figure 13*) can be tested by connecting the transmitter to a 115/200 VAC-400 Hz motor generator. Pin A is the A-phase input and provides power for this board. Pin D is the transmitter neutral. Disconnect the external drive source as the internal timing is used for most of the tests on this board. Disconnect the contactor relay by disconnecting yellow wire at the moxex plug at Board 93.

NOTE: IT IS VERY IMPORTANT THAT THE CONTACTOR BE DISCONNECTED SO THAT HIGH VOLTAGE WILL NOT BE PRESENT ON THE IGBT MODULE DURING TESTING.

Follow the procedure below to determine if the fault lies with this board or with some other part in the transmitter.

NOTE: ALL RESISTANCE MEASUREMENTS SHOULD BE MADE WITH THE TRANSMITTER TURNED OFF.

5.5.1 Power Supply

Verify first that the supply voltages +5 and +/- 12 are present (see the test points on Board 131, *Figure 13*). If they are not within 5% unplug Board 131 and recheck the power supply. If the power supply is still not working, notify Zonge as there are no user serviceable parts on the power supply.

5.5.2 Oscilloscope Setup

Setup a Tektronix model 212 oscilloscope, or similar battery operated or line isolated oscilloscope as follows:

- DC coupled
- 5.0 volt Range
- 1 msec/div
- Channel 2 trigger
- Ground lead on ground wire

5.5.3 Active Filter

Set input voltage to 120 VAC RMS. Setup procedure for the active filter output. This adjustment must be made before any other setup or checkout procedure can be made. With the scope probe tip on the output of pin 6 of H-4 (OP-5) (see TP-0 on *Figure 13*) adjust pot R26 for a 20 VPP (+/- 1 volt) signal at pin 6 H-4.

5.5.4 Phase lock loop

The phase lock loop (D3) is used to multiply the 400 Hz signal to get a resultant frequency of 307,200 Hz (See *Theory of Operation*). Pin 1 on D3 is the in-lock indicator. When the system is in-lock the output of pin 1 of D3 is a 5 volt level signal with a pulse 5.0 microseconds wide going to ground at 2.5 milliseconds intervals. Pin 4 should have a 307,200 Hz square wave with a period of 3.3 microseconds and pin 3 should have a 400 Hz square wave synchronized with pin 14. The output of pin 4 is divided by A3. This results in a 2.4 kHz square wave and a 38.4 kHz signal for the gate drive to the SCR drivers. The 307,200 Hz signal is also divided by C3 (4522) and B3 (4520) to 400 Hz that is the feedback to the phase lock loop for phase comparison with the incoming signal. There will be no output from A3 if reset is high. Reset is generated by the positive-going pulse each time the comparator F4 (CMP01) switches.

5.5.5 Current set point reference

To check the output current set point reference G7 (LH0070) use a digital

voltmeter set for DC input on the 20 volt range. Check the REF output to the current setpoint potentiometer; for a GGT-3 it should be 2.02 volts +/-10mv. Put the probe tip on the Set input from the current setpoint potentiometer and adjust the current set potentiometer from 0.0 to 10.0 divisions. The voltage should vary from 0-2 volts. Check the output of H5 (OP5), the current set buffer, for tracking over the same range.

5.5.6 TRANSMIT/RESET Switch

To check the TRANSMIT/RESET switch, put the scope probe on pin 8 B2 (74C74). The signal will be low for RESET and high for TRANSMIT.

Pin 9 of F3 (4038) should give a two second low pulse each time the TRANSMIT/RESET switch is toggled to TRANSMIT. This is the inhibit time for the contactor to pull in. This reduces the transient pulse which occurs when an unloaded transformer is energized.

5.5.7 Fault Inhibit

Pin 8 of R1 (74C30) should be low after two seconds when the TRANSMIT/RESET switch is toggled toward TRANSMIT, and goes high when the switch is toggled toward RESET. Pin 6 of E2 (74C00) is the inverse. This signal controls the soft start gate and the output gate drive to the SCR bridge. If pin 6 of the E2 does not go high, check the alternator over/under voltage and pin 9 of 74C221 (F3). This should be high for the output of E1 (pin 9) to go low.

5.5.8 Alternator High-Low shut down

This signal also controls the inhibit function. It is generated by the level of the AC voltage from the active filter that feeds H2 (AD536, a true RMS converter). The output should be 10 volts for a 20 volt peak-to-peak AC signal. This is the reference for the transmitter alternator shut down comparators. G1 and H1 should be high if they are in tolerance for correct alternator input voltage (see setup procedure for correct voltages on shut down), i.e. 90 volts for low shut

down and 130 volts for high shut down.

If the outputs to E1 are both high but pin 6 of E2 is still low, check the FL-EXT.FAULT input at the lower edge of Board 131. This is the fault input from Board 93. It will also inhibit Board 131.

5.5.9 Soft Start

This is an open collector pull-up to inhibit the feedback integrator. By pulling up pin 3 of F5 through R 30, the integrator shuts down. Put the scope probe on pin 6 of F5 and toggle the TRANSMIT/RESET switch. The output should remain high in RESET and drift negative on TRANSMIT.

5.5.10 Current Feedback

The output of F5 is compared to the reference waveform from the active filter by comparator F4 (CMP-01). As long as pin 6 of F5 is greater than 10 volts, there is no output from F4. As pin 6 goes more negative the output of F4 switches from 0.0 to 5.0 volts as the sinewave crosses the level of the pin 3 input. Normally the output of the isoamp drives this input that regulates the output current. In the test mode, the output of the integrator will swing from +10V to -10V. As it swings, the output of the comparator (pin 7 of F4) will sweep from zero volts to a 400 Hz square wave after the two second delay. This happens each time the TRANSMIT/RESET switch is toggled.

The output of comparator F4 (pin 7) goes to pin 2 of F2. This is a one shot multivibrator (74C221). Pin 13 is the Q output which resets A3 (see the phase locked loop section). QNOT (pin 4) also triggers pin 10 of F2 which provides a low inhibit pulse of 1.6 microseconds to keep the A half of F2 (74C221) from retriggering at the 180 degree point of the reference waveform.

Pins 4 and 8 of F2 (74C221) provide the reset pulses to the main counter A3 and the shift register D2, C2 and D1. This shifts the firing angle information through the SCR drive gates B2 and C1.

Pin 13 of F2 is compared with the 400 Hz square wave from the comparator H3 (CMP01). If the phase position of pin 13 of F2 as compared to the 400 Hz input is greater than 90 degrees, then the end of regulation light is turned ON. In test mode with the current set point at zero, the End-of-Regulation light should extinguish momentarily two seconds after going to transmit and then come ON again. Toggle the transmitter RESET switch on and off to insure that this is happening.

5.5.11 SCR driver wave forms

Look at pin 9 of A2 (88C29). As the TRANSMIT/RESET switch is toggled to TRANSMIT, a waveform as shown in *Figure 14* of 38.4 kHz and 0.8 milliseconds wide should be found on pins 5 and 9 of A2 and on pins 5, 6, 8, and 9 of B1. These are the SCR drive waveforms. Each waveform is shifted in time from the previous one by 0.4 milliseconds from 1 to 6 in the SCR outputs. This is the firing sequence for the SCR controlled bridge (*Figure 15*).

5.5.12 Duty cycle input

With The TRANSMITTER CONTROLLER (Zonge XMT-12) connected to EXT control, set the TRANSMITTER CONTROLLER for a 256 Hz 50% duty cycle time domain signal.

The input to Board 131 should be a 512 Hz square wave at DUTY on the upper right corner of the board. Check the duty cycle output to the isoamp. This is a buffered output from Board 131. It controls the sample and hold on the isoamp. Switch the TRANSMITTER CONTROLLER to 1 Hz and set the current set potentiometer to 5.00. On the GGT-3 it will be 1.0 volt at "Set". Pin 1 of F6 (IH5042) should switch between 0.0 and 1.0 volt. This checks the integrate and hold function for the pulse variable outputs. If there is no switching, check pin 16 of F6 for 0.0 volts and pin 4 for 1.0 volt. If pin 16 is not 0.0 but pin 3 of F7 is 0.0, this indicates a bad IH5042.

The remaining circuits are for the open circuit shutdown and input overcurrent. The two circuits work together and cause the same type of fault latch.

Input overcurrent shut down is set by B5 CMP-01 and is adjusted for 9 amps on the input at phase A. This will be about 0.51 volts DC at the output of the RMS converter B6-AD536. Adjust R35 until the input overcurrent light turns ON.

Open circuit shut down is set by setting the output current to 0.200 amps on the 250 volt tap with a 100 ohm load, and adjusting R32 until the open circuit lamp turns ON. Reset transmit and try again. Make sure that you can start transmitting when the current is at 0.500 amps.

5.6 Power Supply

Refer to the power supply data sheet in the back of this manual for test points and voltages. Remove the output connector before measuring the voltages. Check the input first to insure that the circuit breaker, control power switch, and generator are O.K.

If any voltages are out of tolerance, return the supply to Zonge. They have no user serviceable parts and are covered by a one-year manufacturer's warranty.

5.7 Loop Switch

This option is used when the GGT-3 is used to drive loops or long grounded dipoles in the time domain or transient E.M. mode. It is only operational in this mode and cannot be used in Frequency Domain. When the signal that turns off the output is received, an SCR across the output is fired and a 120 ohm 50 watt resistor is connected to the loop. This provides damping for transients occurring in the loop at turnoff.

6 APPENDIX

6.1 Checking Phase Sequence - Alternator

NOTE: This test should be made at the military plug on the end of the transmitter power cable that plugs into the transmitter (*Figure 16*). This insures that all of the wiring is correct between the alternator and the input to the transmitter.

6.1.1 Use a DVM (Fluke) to check the absolute voltages on each phase.

Set the Fluke to: AC
 200 volt range

6.1.2 Place the ground lead of the Fluke on the neutral lead of the plug, i.e. lead "D" (*Figure 16*). Place the positive Fluke lead on leads (phases) A, B, and C (*Figure 16*) in turn and record the voltages for each phase. The voltages should all be within 10% of each other.

6.1.3 NOTE: When you measure the 3-phase voltages as indicated above, if one of the phases measures the normal 110 to 120 volts and the other two phases measure approximately 200 volts, the lead "D" is not connected to "neutral" on the alternator. If you attempt to bring up the transmitter with the alternator in this configuration, serious damage will result.

6.1.4 Set a Tektronix 212 or similar oscilloscope as follows:

6.1.5 TRIGGER SOURCE CH2

TRIGGER LEVEL AUTO
SEC/DIV 0.5m
VOLTS (BOTH Ch1 and Ch2)..... 50
INPUT COUPLING AC

6.1.6 Connect the ground lead on the Ch2 probe on the oscilloscope to the neutral lead (*Figure 16*) on the military plug.

6.1.7 Bring up to 120 volts using the voltage regulator.

WARNING: POTENTIALLY FATAL VOLTAGES ARE NOW PRESENT ON THE OUTPUT LEADS ON THE MILITARY PLUG.

- 6.1.8 Carefully place the Ch2 probe on pin A ("A" phase) on the military plug (*Figure 16*). Adjust the VOLTS/DIV VAR knob to achieve a peak-to-peak signal of four divisions. Adjust the HORIZ MAG knob to achieve a peak-to-peak signal of six divisions. Adjust the horizontal POS knob to adjust the waveform as shown in *Figure 17.1*.
- 6.1.9 The correct phase sequence is: B lags A and C lags B, both by 120 degrees. Keep the Ch2 probe on the A phase and place the Ch1 probe on the B phase (*Figure 16*). If you have the waveform on the oscilloscope such that the horizontal peak-to-peak signal is six divisions (*Figure 17.1*), then each division is equal to 60 degrees. Therefore, the B phase signal (Ch1) should be two divisions to the right of phase A (*Figure 17.2*). If the phase sequence is not correct, the B phase will lead the A phase by 60 degrees (*Figure 17.3*).
- 6.1.10 If the B phase leads the A phase (*Figure 17.3*), reverse any two of the transmitter power cable leads on the alternator and repeat *Section 6.1*.
- 6.1.11 Keep the Ch2 probe on the A phase and place the Ch1 probe on the C phase. The C phase should lag the A phase by 240 degrees, i.e. the C phase should be four divisions to the right of the A phase (*Figure 17.4*).

GGT-3 TRANSMITTER

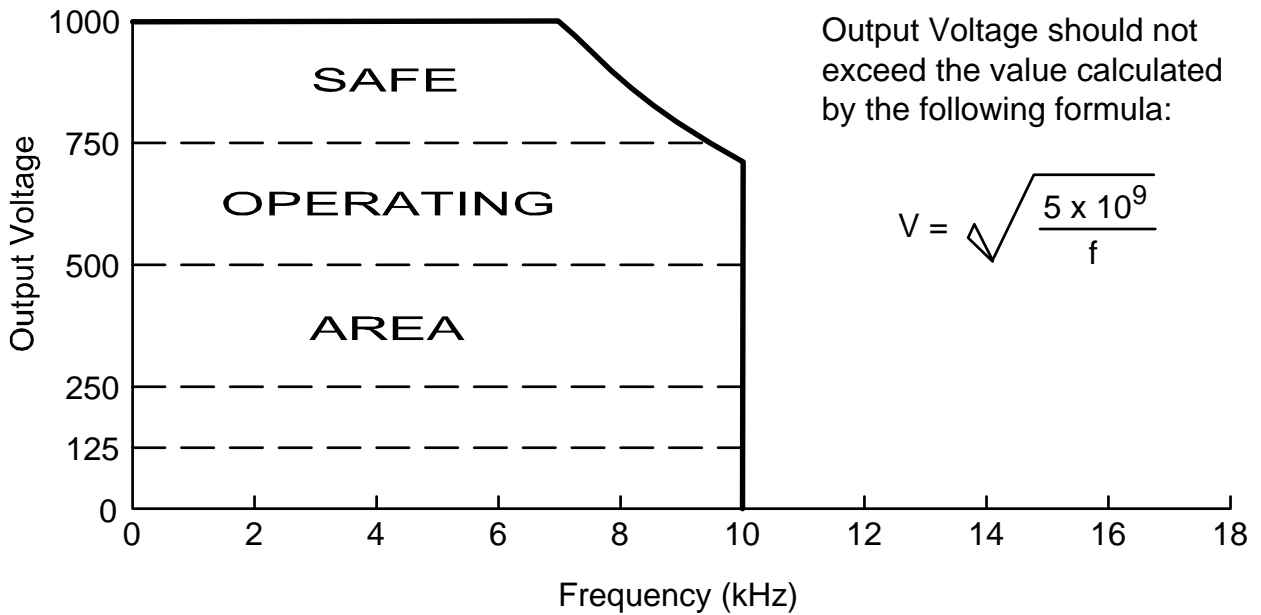
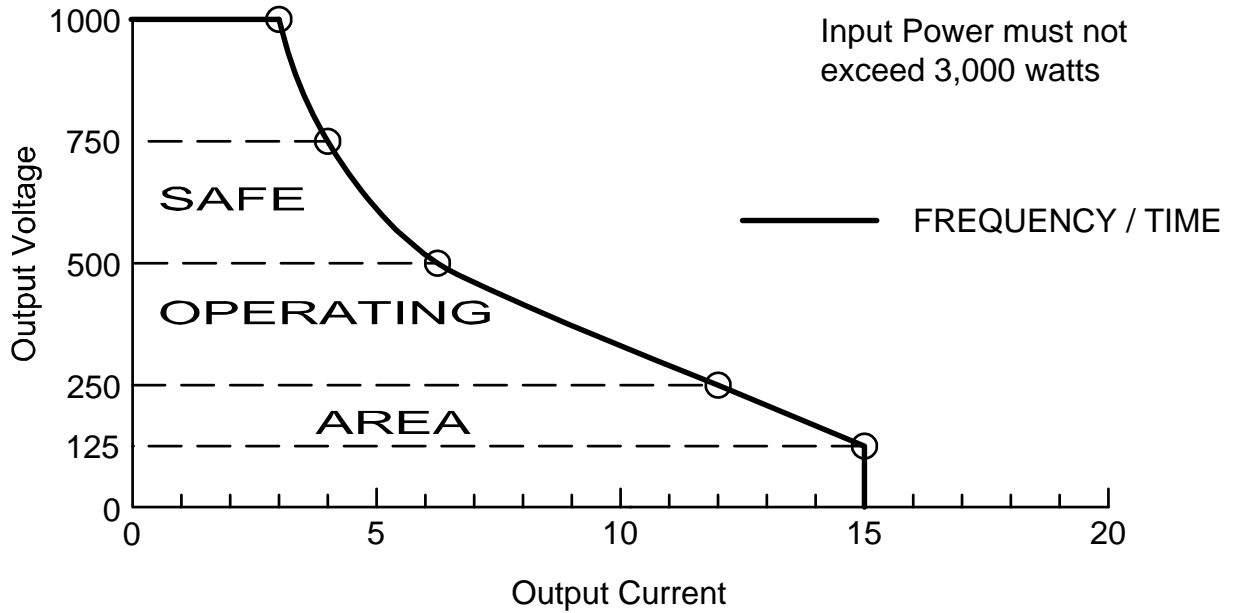
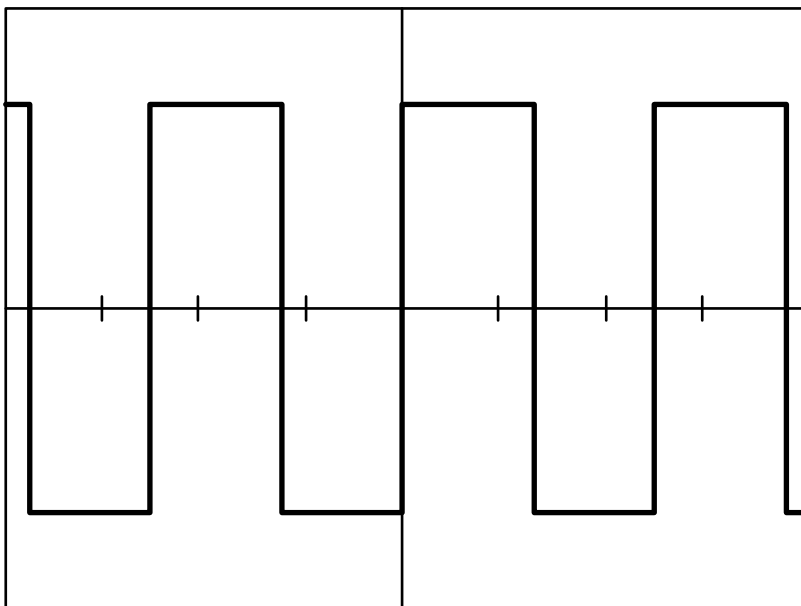
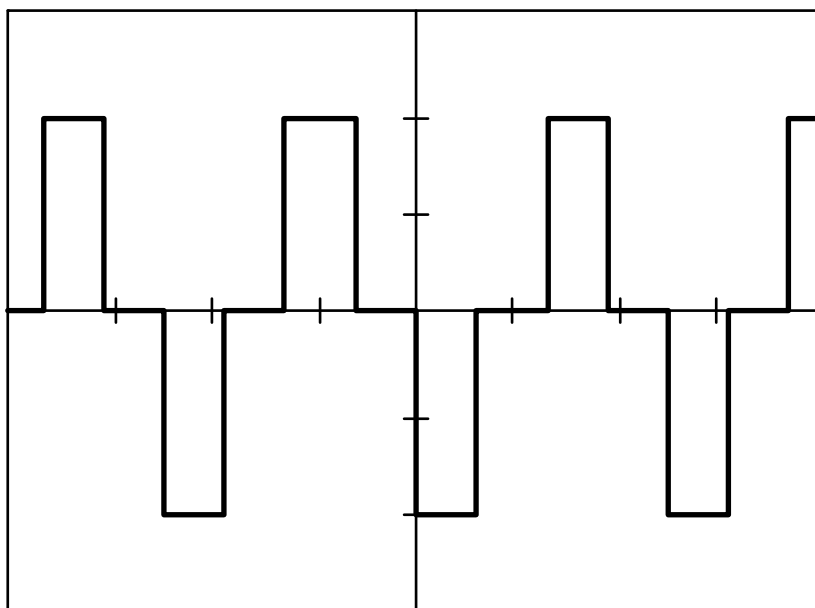

Figure 1. Safe Operating Curves for GGT-3

Fig01.wmf



8 Hz Frequency Domain 100 Volts / div 50 msec / div



8 Hz Time Domain 100 Volts / div 50 msec / div

50% duty cycle

Figure 2. Output Waveforms

Fig02.wmf

GGT-3 TRANSMITTER

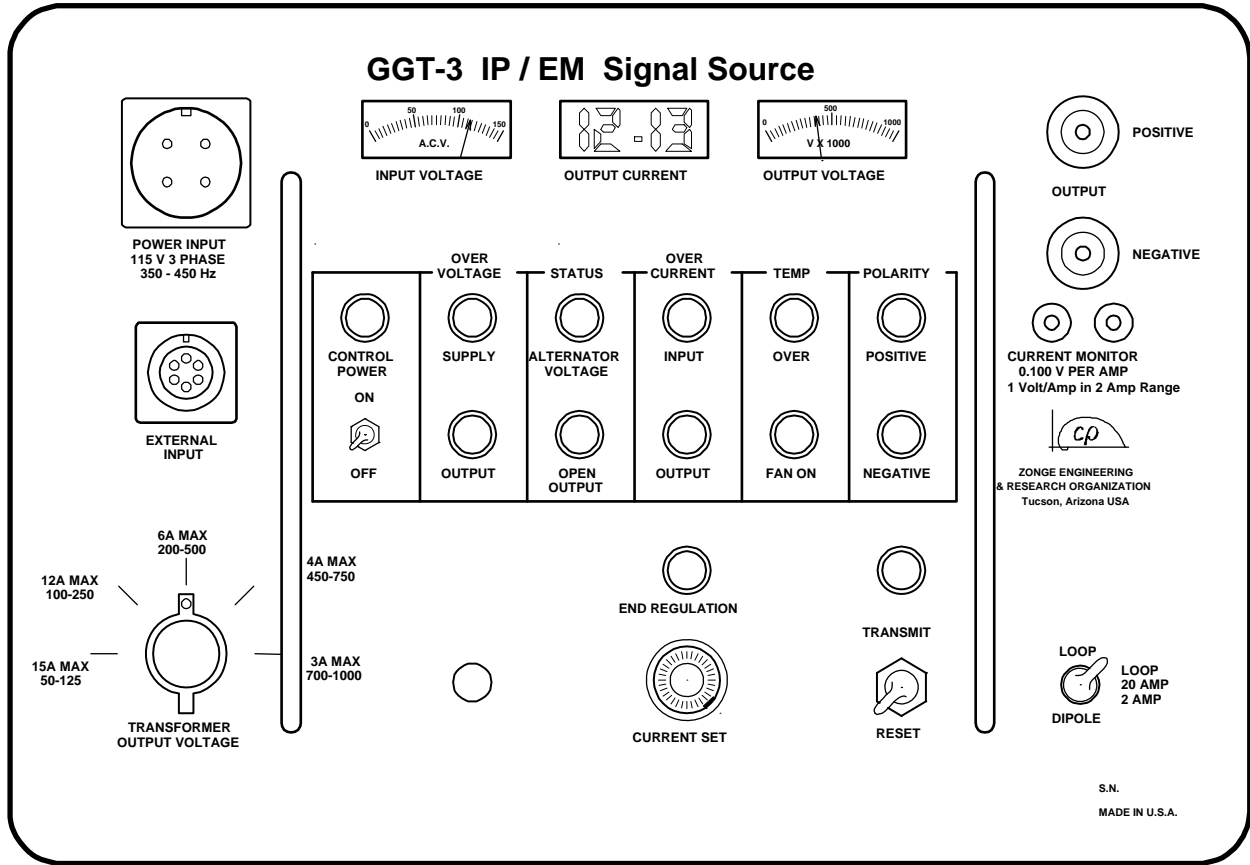

Figure 3. GGT-3 Front Panel

Fig03.wmf

GGT-3 TRANSMITTER

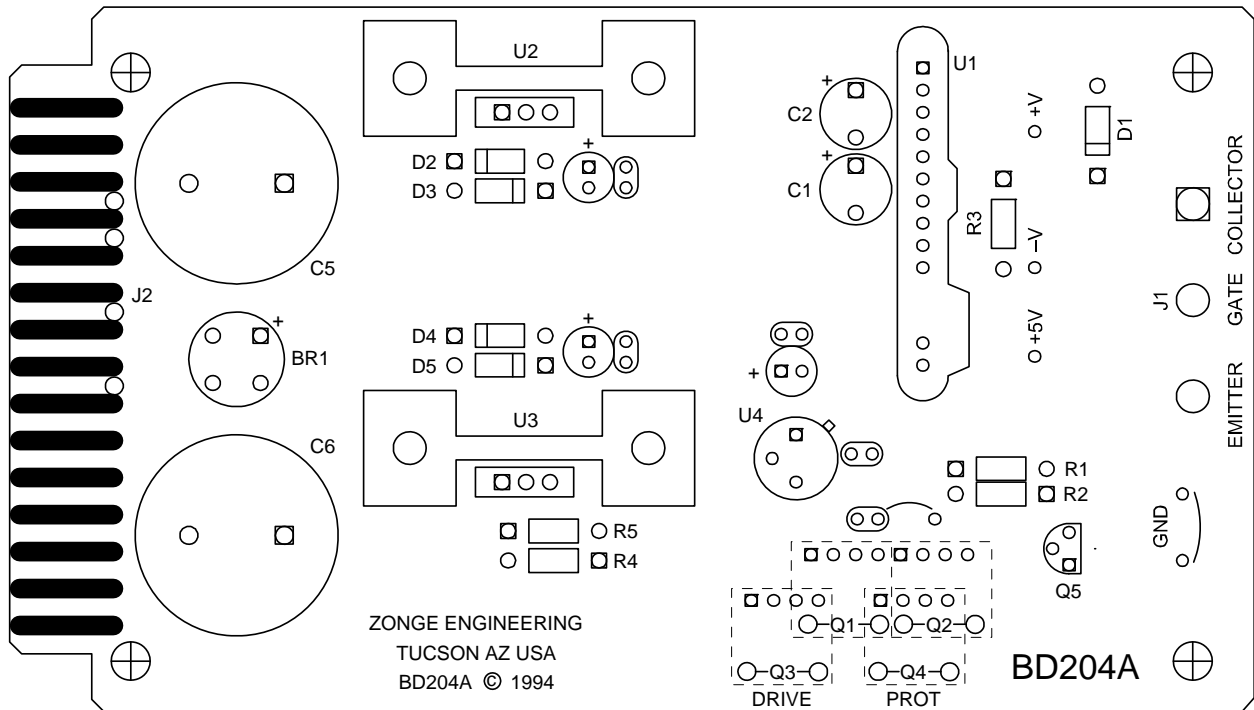

Figure 4. Board 204

Fig04.wmf

BD204 SILKSCREEN BD204 SOLDER MASK

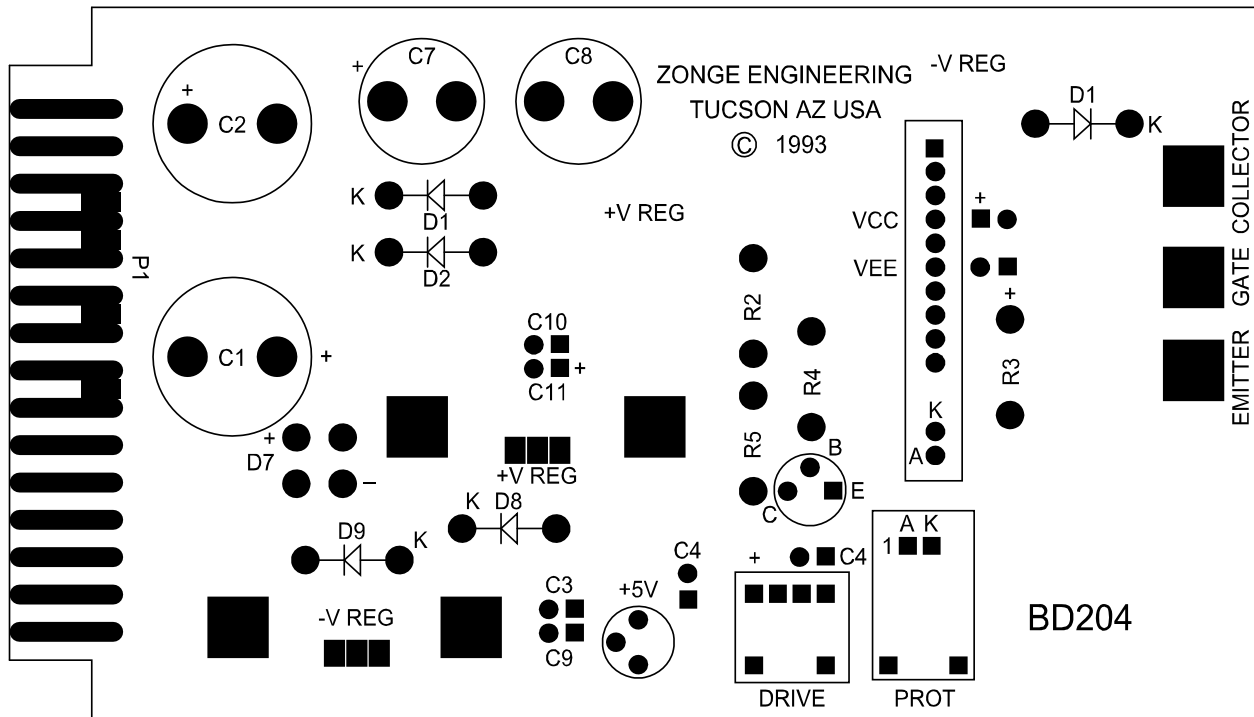

Figure 5 Board 204

Fig05.wmf

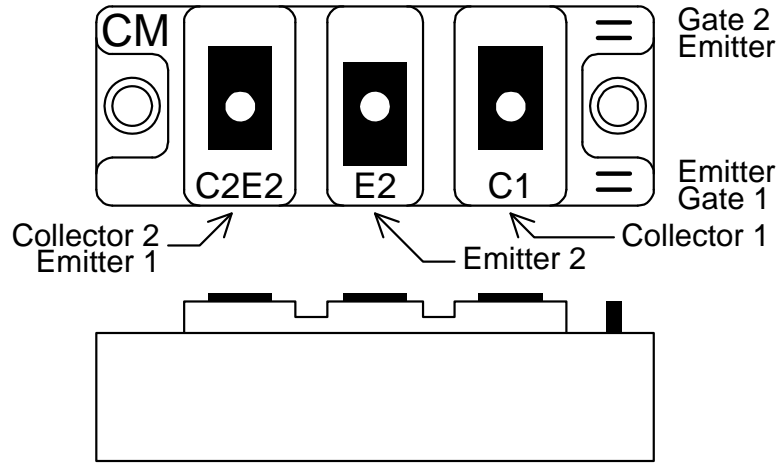

Figure 6a: IGBT

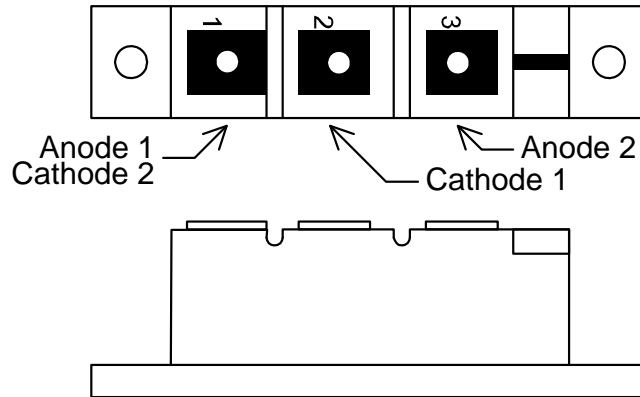

Figure 6b: Diode

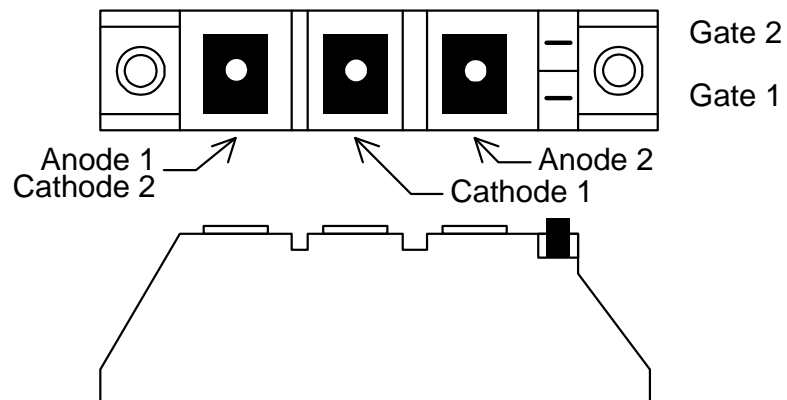

Figure 6c: SCR

Figure 6 IGBT Diode and SCR illustrations

Fig06.wmf

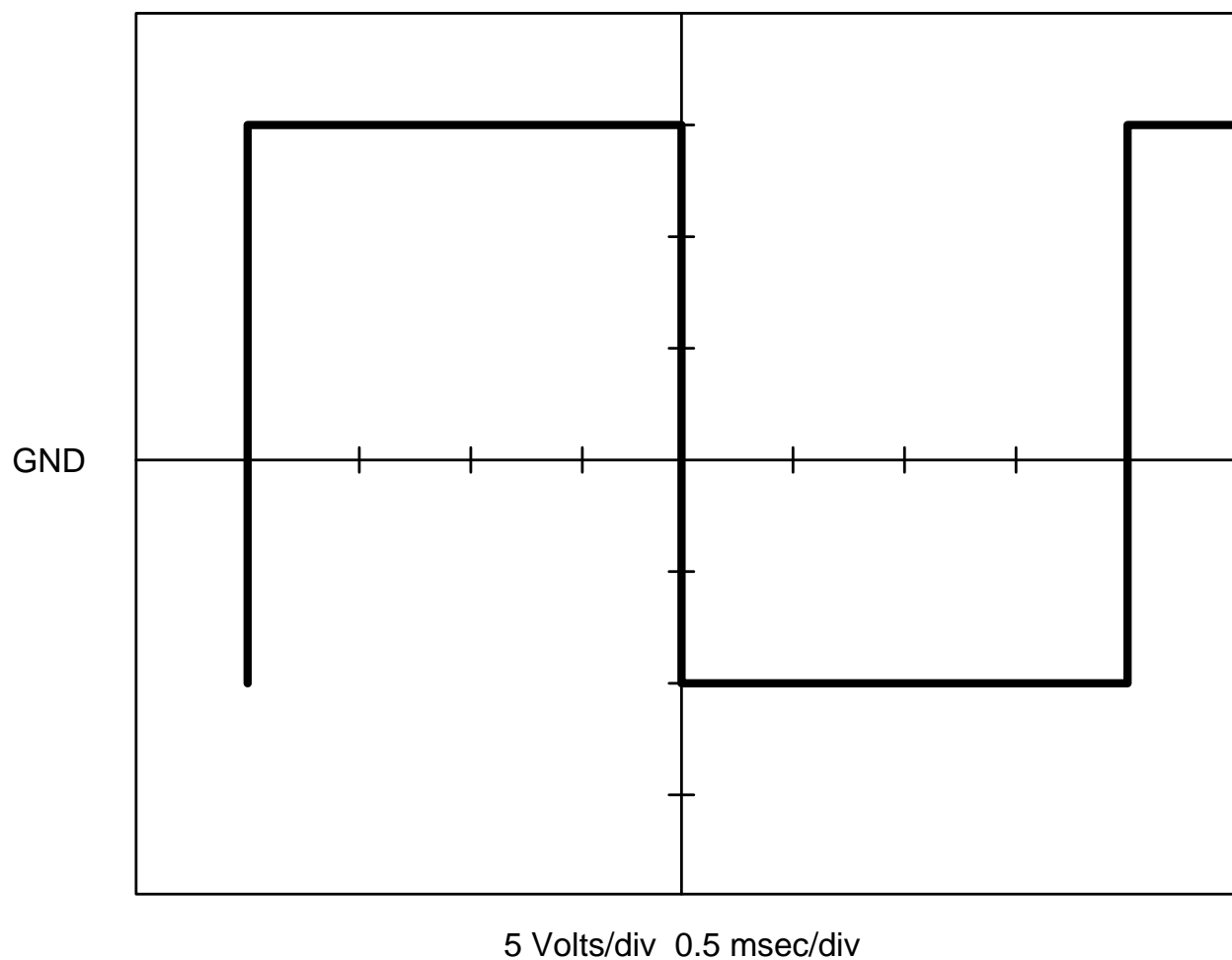

Figure 7. IGBT Drive Waveform (+15V/-10V)

Fig07.wmf

GGT-3 TRANSMITTER

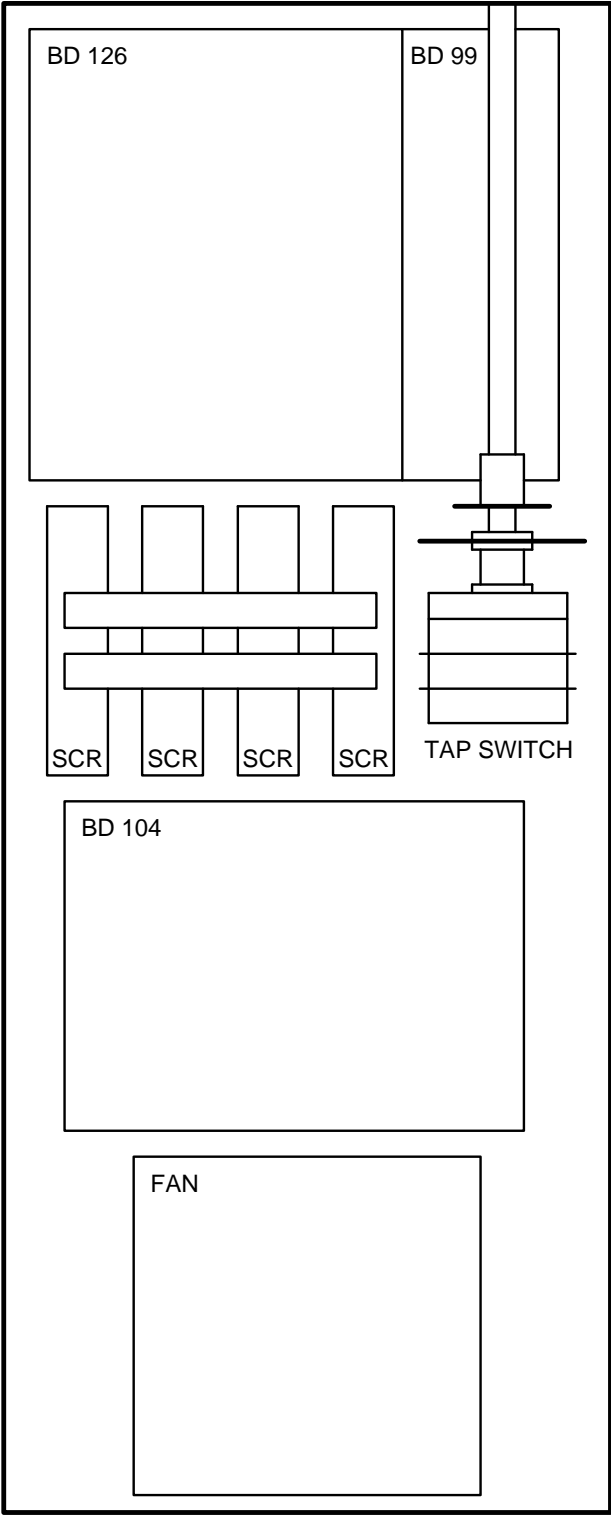

Figure 8. GGT-3. Left Side

Fig08.wmf

GGT-3 TRANSMITTER

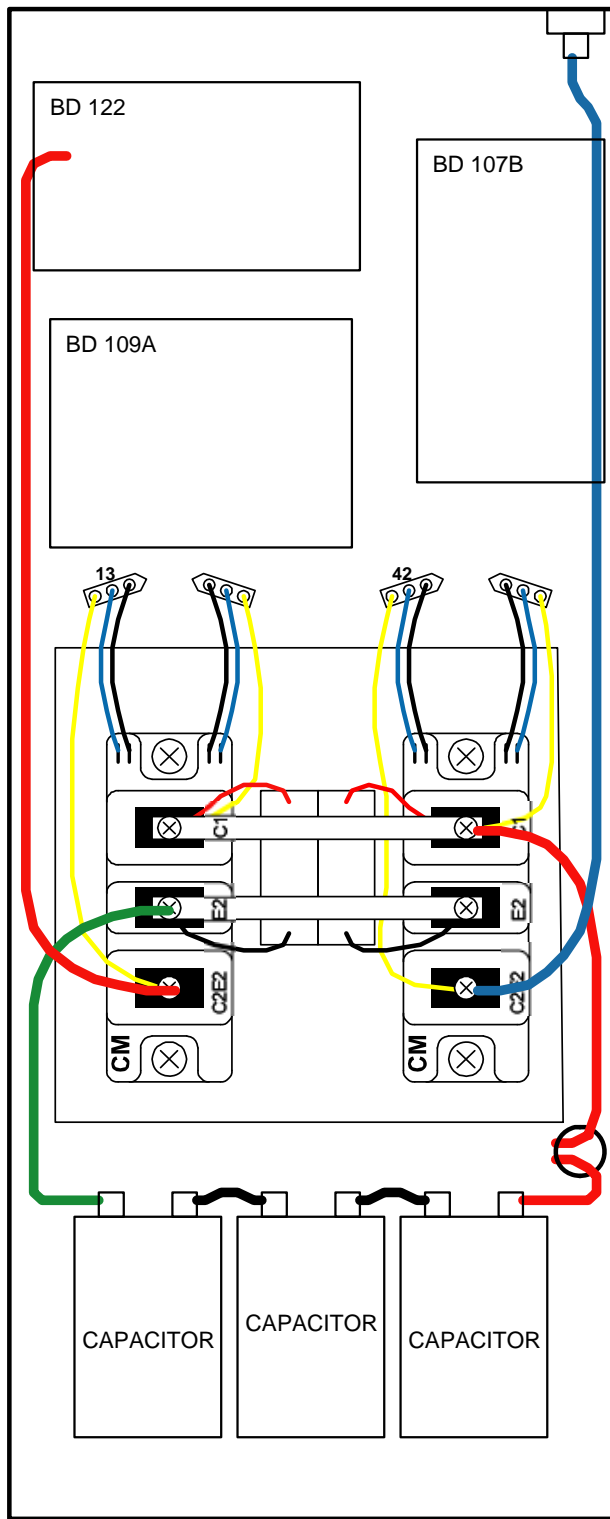

Figure 9. GGT-3, Right Side

Fig09.wmf

Figure 10. (Reserved)

Fig10.x

GGT-3 TRANSMITTER

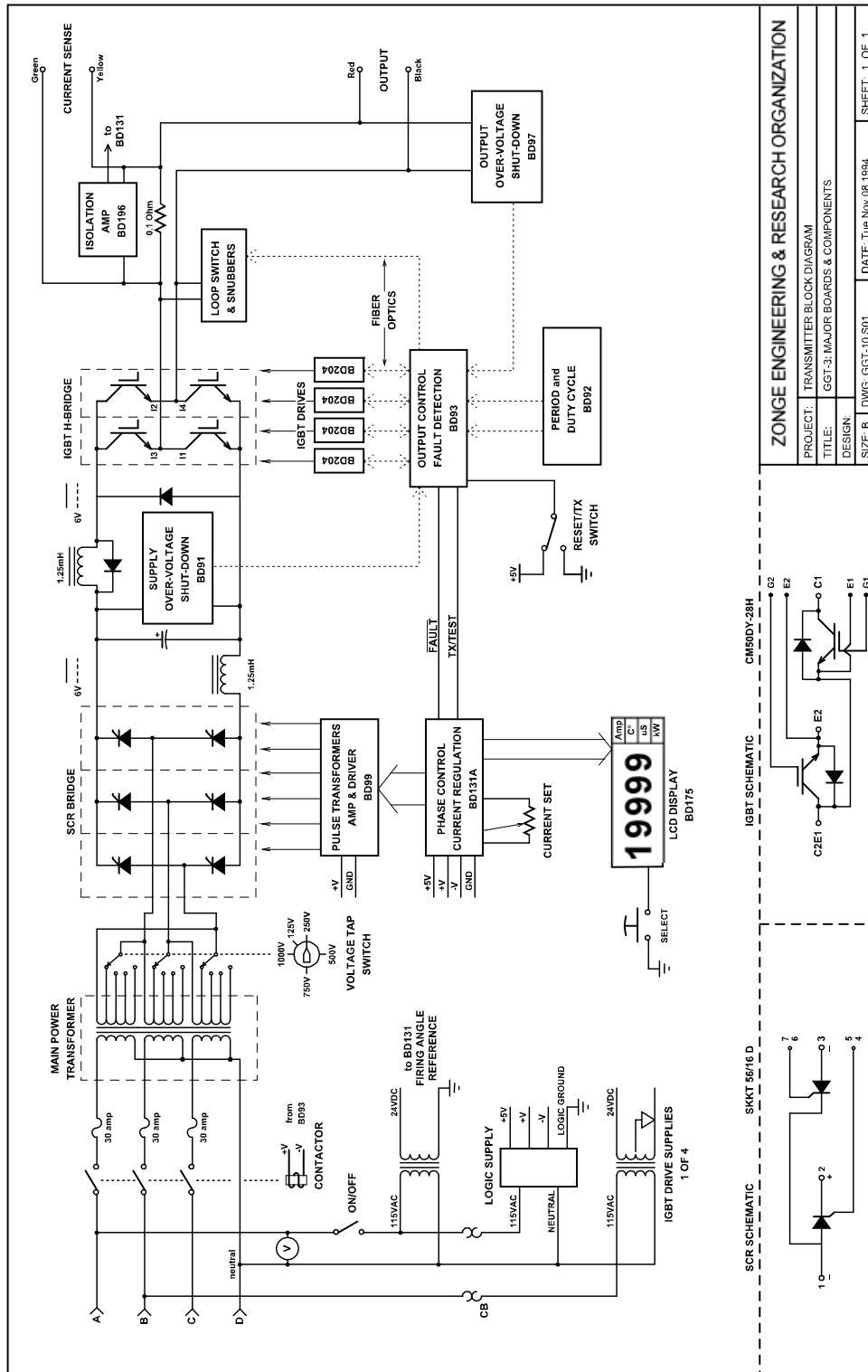

| | | | |
|--|----------------------------------|------|---------------|
| ZONGE ENGINEERING & RESEARCH ORGANIZATION | | | |
| PROJECT: | TRANSMITTER BLOCK DIAGRAM | | |
| TITLE: | GGT-3: MAJOR BOARDS & COMPONENTS | | |
| DESIGN: | | | |
| SIZE: | B | DWG: | GGT-10.S01 |
| DATE: | Tue Nov 08 1994 | | SHEET: 1 OF 1 |

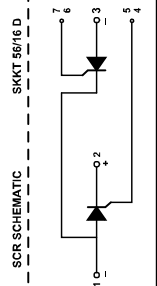
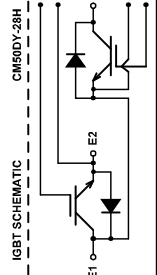

Figure 11. GGT-3, Block Diagram

Fig11.wmf

GGT-3 TRANSMITTER

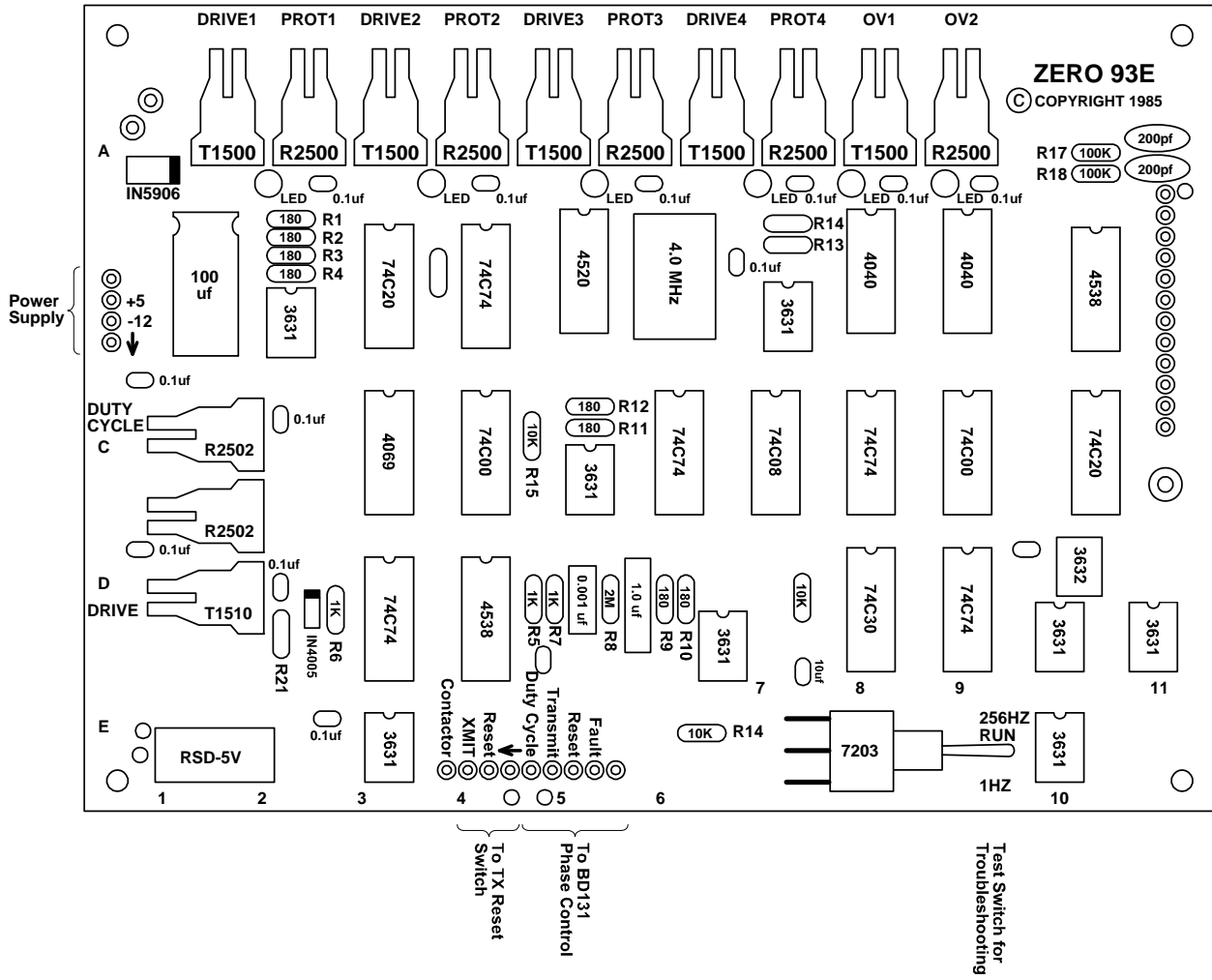

Figure 12. Board 93, Switching Control

Fig12.wmf

GGT-3 TRANSMITTER

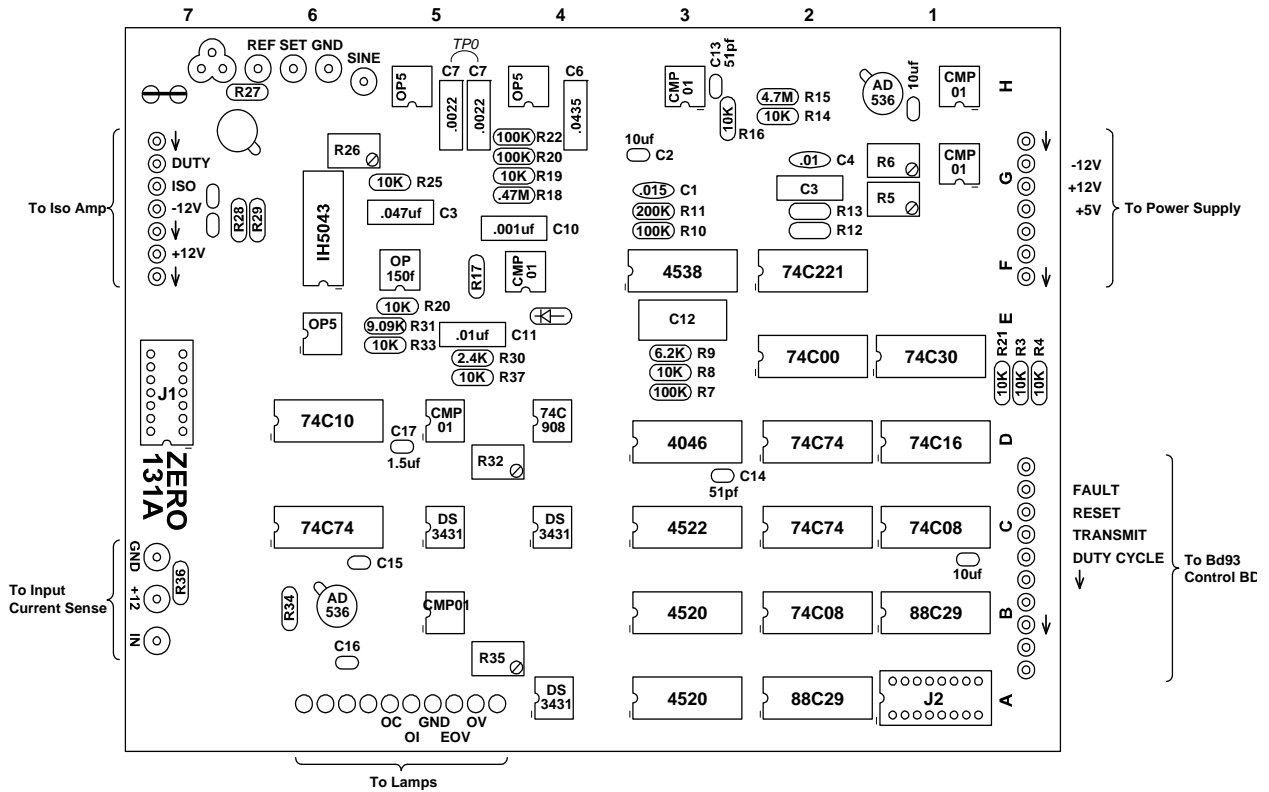

Figure 13. Board 131, Phase Control & Protection

Fig13.wmf

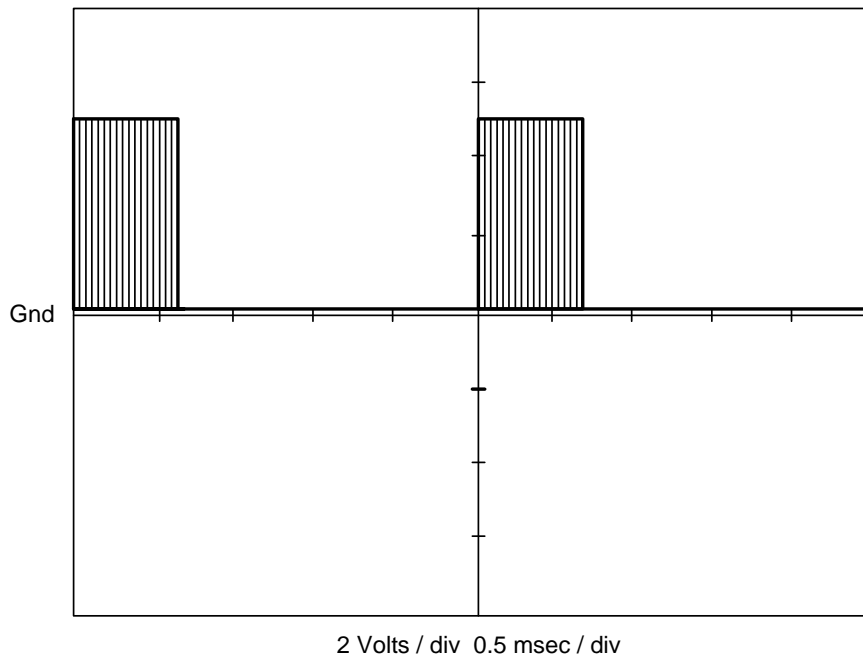

Figure 14. SCR Driver Waveform, 38.4 Khz Burst

Fig14.wmf

GGT-3 TRANSMITTER

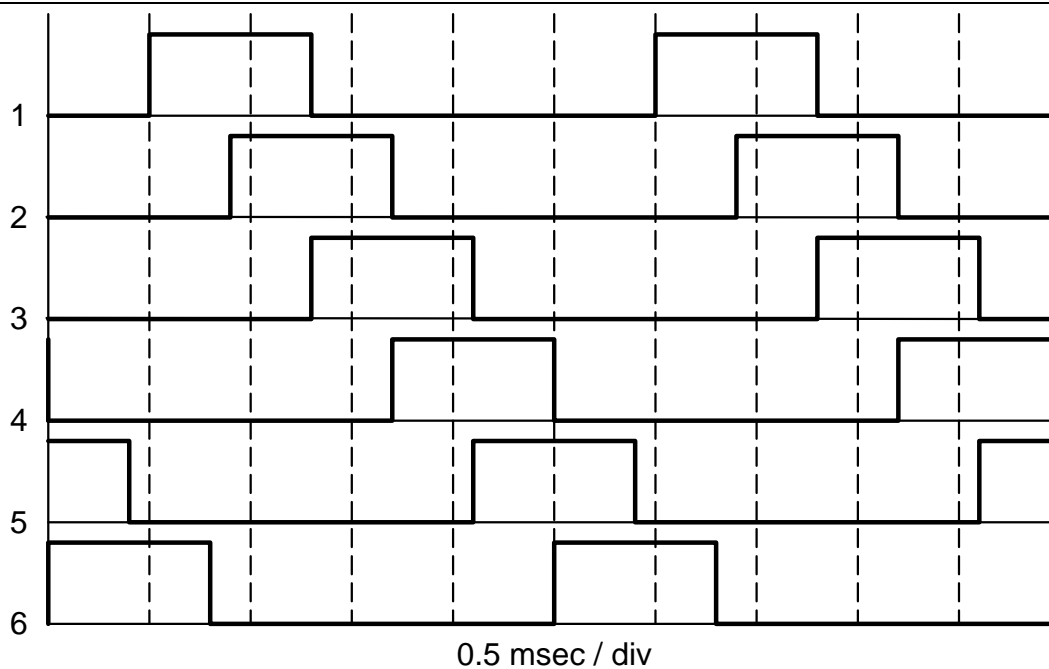

Figure 15. SCR Firing Sequence

Fig15.wmf

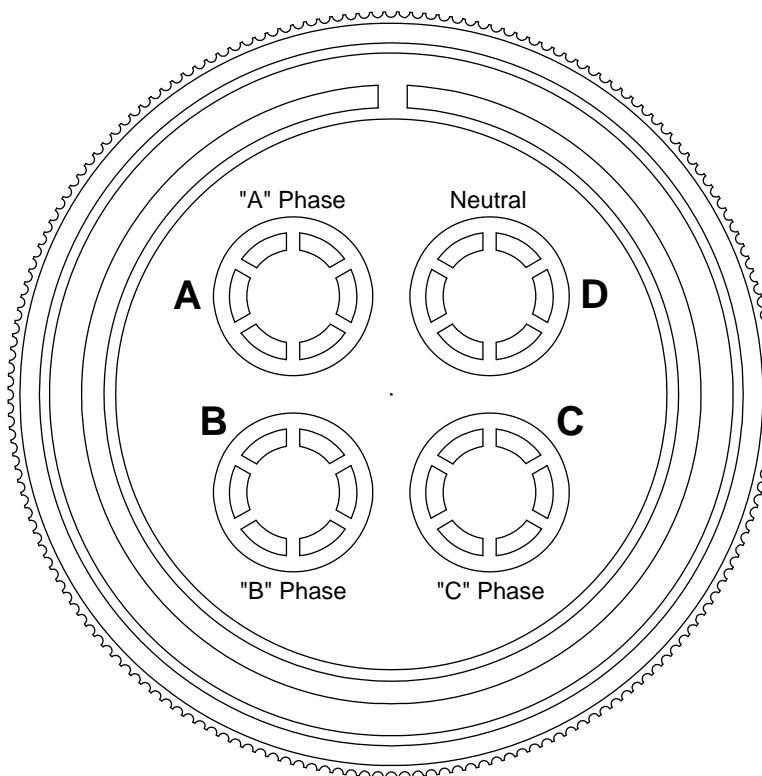

Figure 16. Power Cable, Military Plug, Transmitter end

Fig16.wmf

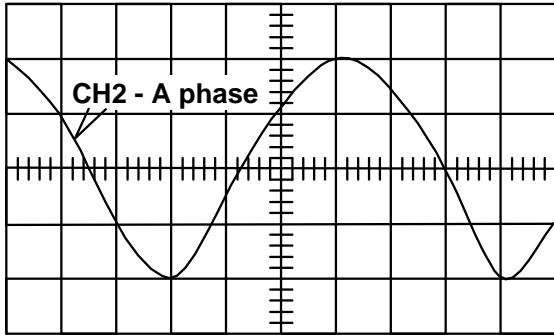

Figure 17.1 Adjust oscilloscope so that the A - phase waveform matches this diagram.

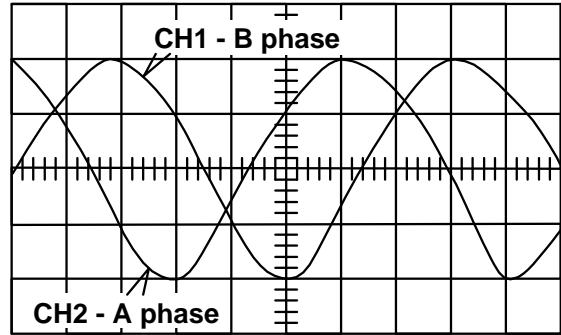

Figure 17.2 Correct phase relation for A and B phase.

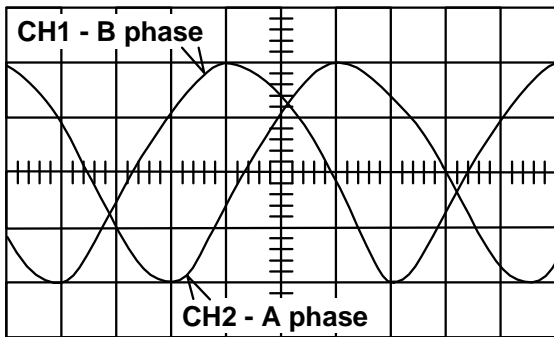

Figure 17.3 Incorrect phase relation for A and B phase.

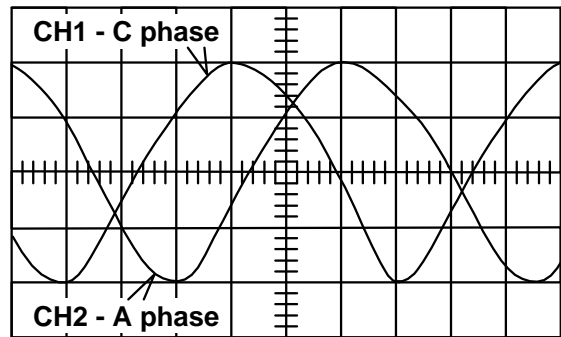

Figure 17.4 Correct phase relation for A and C phase.

Figure 17. Power Cable Phase Diagrams

Fig17.wmf

GGT-3 TRANSMITTER

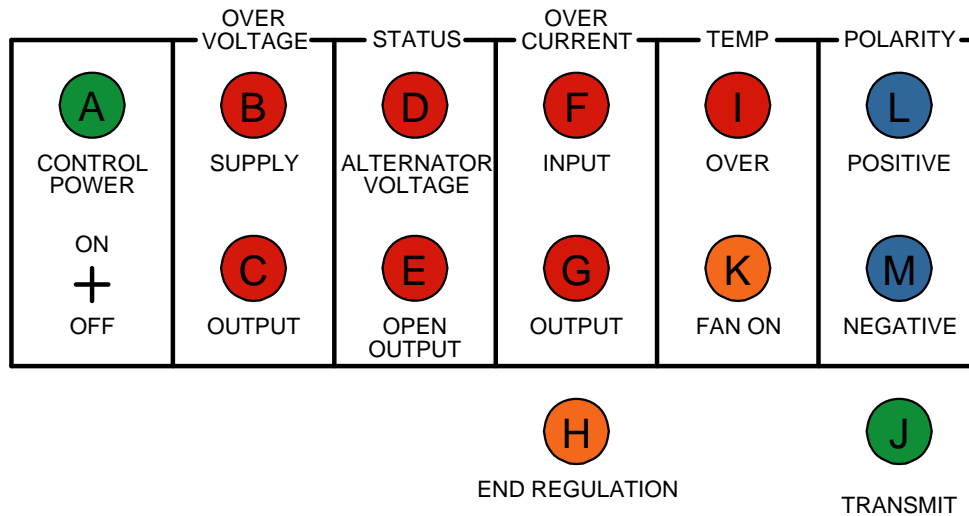

Figure 18. Front Panel Lamp Functions

Fig18

All lights (except TRANSMIT) turn ON when POWER is switched ON (lamp test). RESET turns them OFF, except for the ON and END REG. lights.

- a) **CONTROL POWER** Power ON. The DC supplies and control circuits are powered up.
- b) **SUPPLY** This light indicates that the high voltage supply has reached 1,000 volts. Resets transmitter. Check for excessive input voltage.
- c) **OUTPUT** This light indicates an output voltage of 1,000 volts. Resets transmitter. At the highest frequencies, loads can look inductive and cause spikes that trip this circuit. Adjust current down.
- d) **ALTERNATOR VOLTAGE** This indicates that the input voltage is out-of-range or a possible phase loss.
- e) **OPEN OUTPUT** Output current is too low. Measure electrode resistance to check for an open circuit. Current setting may be too low.
- f) **INPUT** The input power is limited to transmitter power specifications. Resets transmitter. Possible input phase loss. Transmitter is most efficient near the top of each tap switch range.
- g) **OUTPUT** This indicates an overcurrent condition in the output circuit. Resets transmitter. If transmitting into a loop (very low resistance), it may be necessary to use a dummy load in series. If the light does not reset, a GTO or GTO drive board has failed.
- h) **END REGULATION** This light is OFF only when the output is regulated. The output should be regulated through the range of each tap setting. A narrow range of regulation could indicate loss of a phase, incorrect control settings, or low input voltage.
- i) **OVER** Shuts off TX if transformer temperature exceeds 80°C (176°F).
- j) **TRANSMIT** This indicates power at the electrodes.
- k) **FAN ON** On a GGT-3, the fan is ON when the control power light is ON.
- l) **POSITIVE** After RESET, this light shows the polarity of the output.
- m) **NEGATIVE** After RESET, this light shows the polarity of the output.

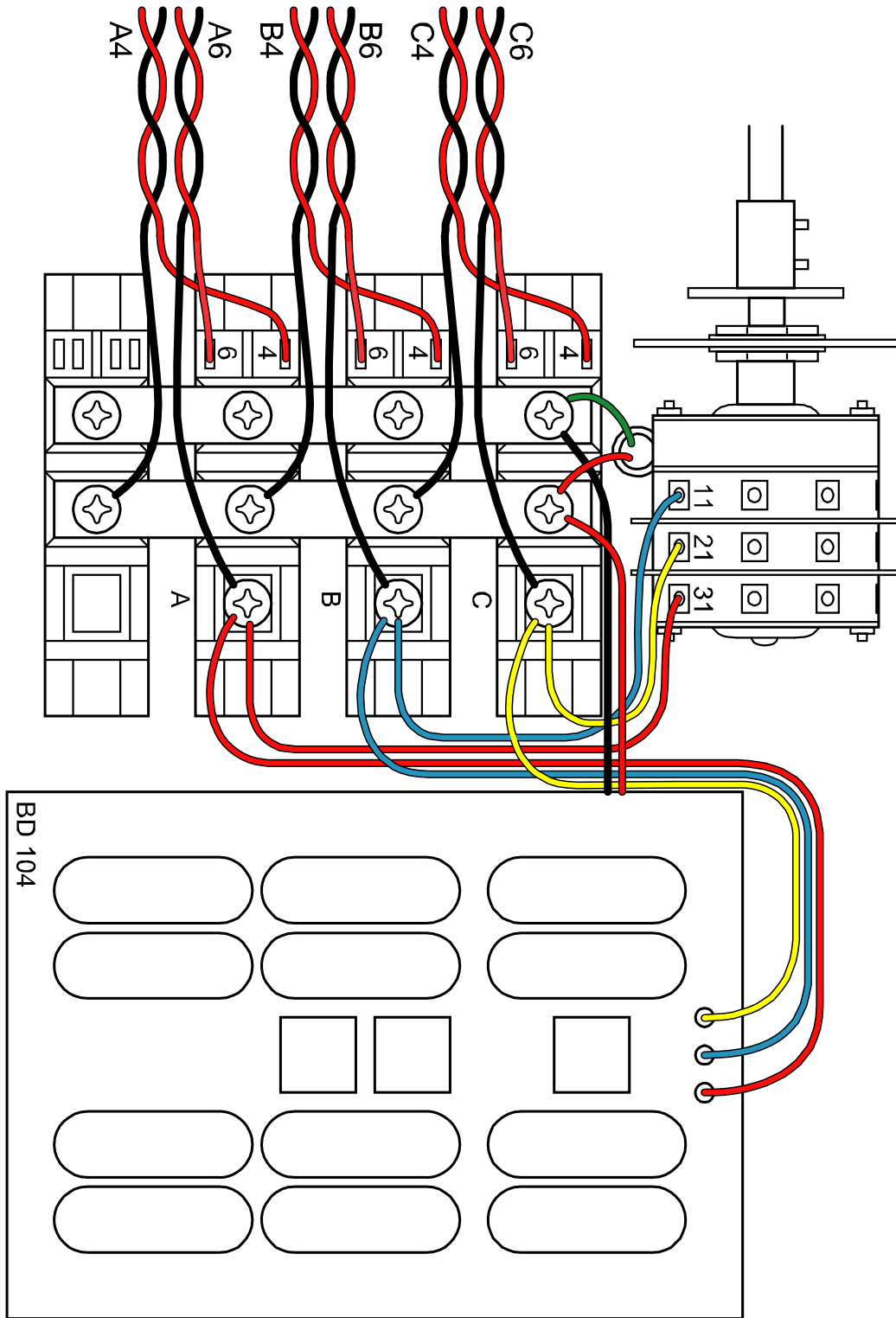
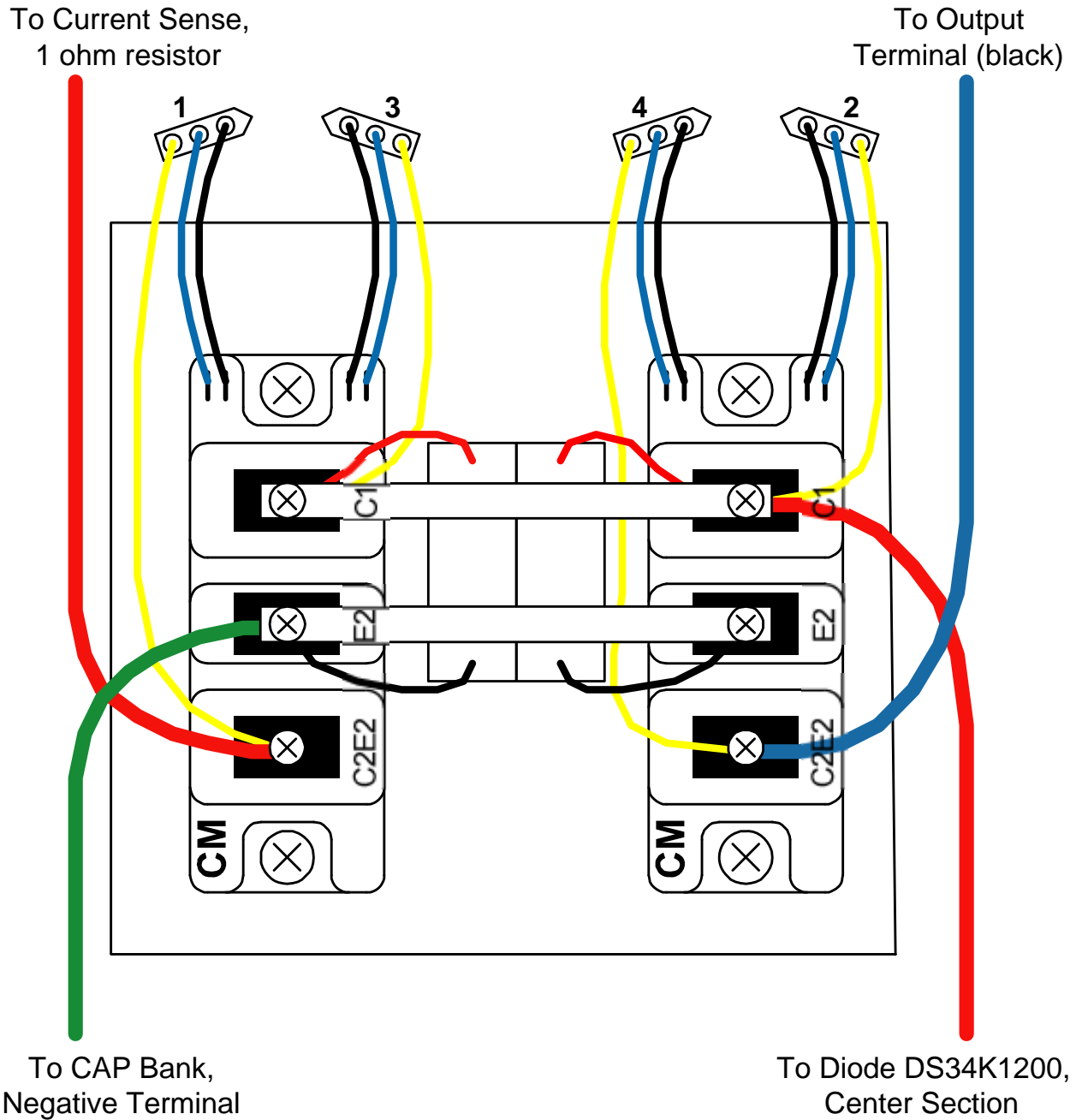

Figure 19. GGT-3, SCR Wiring Diagram

Fig19.wmf



To Current Sense,
1 ohm resistor

To Output
Terminal (black)

To CAP Bank,
Negative Terminal

To Diode DS34K1200,
Center Section

Figure 20. IGBT Heat Sink Wiring Diagram

Fig20.wmf

40W**OPEN-FRAME SWITCHING POWER SUPPLIES**

- ✓ Single, Dual and Triple Output Models
- ✓ Universal AC-Input and DC-Input Models
- ✓ CE Mark: UL/CSA/EN60950 Approvals
- ✓ BABT Approvals
- ✓ Austel CCL Certification
- ✓ EN55022/FCC Class B Input Line Filter
- ✓ 0% Minimum Load Requirement
- ✓ Over-Current/Short-Circuit Protection
- ✓ 2-Year Warranty
- ✓ Minimum 200,000-Hour MTBF

**CHARACTERISTICS**

| | |
|-------------------------------------|--|
| Input Voltage | FLU models, universal input range 85-265 VAC single phase or 100-370 VDC. DC input models, 36-75 VDC (48V, nominal). |
| Input Line Frequency | FLU models, 47-440 Hz (50-60 Hz, nominal). |
| Input Line Protection | MOV transient protected (FLU series). Input line fuse provided on-board. (See Note 1.) |
| EMI Filter | Standard. Performance surpasses conducted EMI requirements of EN55022/FCC Class B by 10 dB, typ. |
| DC Output | See table. (Note 2.) |
| Continuous Output Power | 40W, maximum. |
| Output Voltage Adjust | Primary output adjustable $\pm 5\%$. Auxiliary outputs fixed. |
| Efficiency | 62-75%, typical (nominal input line voltage, nominal load conditions). |
| Hold-Up Time | FLU models: 16 ms (115 VAC input), 32 ms (230 VAC input), minimum, at full load |
| Overload Protection | Power-limit circuit. |
| Short-Circuit Protection | Continuous. |
| Over-Voltage Protection | Primary output only. |
| Soft Start | Standard on all models. |
| Design Topology | Flyback converter with current-mode control. |
| Frequency of Operation | 40 kHz (fixed). |
| Electrical Strength/Isolation | 5300 VDC, input-to-output for one minute. (Note 6.) |
| Noise, Ripple and Spike | 1% peak-to-peak, maximum. (See Note 8.) |
| Temperature Range | -20°C to +70°C. |
| Output Power De-Rating | De-rate output power and current linearly 2%/°C from +50°C to +70°C. |
| Temperature Coefficient | $\pm 0.05\%/^{\circ}\text{C}$ over the entire operating temperature range. |
| Relative Humidity | 0 to 95%, non-condensing. |
| Altitude | 0 to 10,000 feet. |
| Cooling | Convection cooling is adequate. Moving air is recommended for operation in a confined area. |
| Storage Temperature | -40°C to +85°C. |
| Storage Humidity | 0 to 95%, non-condensing. |
| Mean Time Between Failures | >200,000 hours. (Note 9.) |

| Model | Output Voltage Output (V) | Output Current | | | Output Voltage | | | Line Reg. | Load Reg. | Cross-Reg. |
|---------------------------------------|---------------------------|----------------|----------|-------------------|----------------|----------|----------|-----------|-----------|------------|
| | | Min. (A) | Nom. (A) | Max. (A) | Min. (V) | Nom. (V) | Max. (V) | | | |
| AC-DC Singles 85-265 VAC Input | | | | | | | | | | |
| FLU1-40-1AD | V1 5 | 0.0 | 8.00 | 8.00 | 1.0% | 0.1% | 0.2% | — | — | — |
| FLU1-40-2AD | V1 9 | 0.0 | 4.40 | 4.40 | 1.0% | 0.1% | 0.2% | — | — | — |
| FLU1-40-3AD | V1 12 | 0.0 | 3.30 | 3.30 | 1.0% | 0.1% | 0.2% | — | — | — |
| FLU1-40-4AD | V1 15 | 0.0 | 2.70 | 2.70 | 1.0% | 0.1% | 0.2% | — | — | — |
| FLU1-40-5AD | V1 24 | 0.0 | 1.70 | 1.70 | 1.0% | 0.1% | 0.2% | — | — | — |
| FLU1-40-6AD | V1 28 | 0.0 | 1.40 | 1.40 | 1.0% | 0.1% | 0.2% | — | — | — |
| AC-DC Duals 85-265 VAC Input | | | | | | | | | | |
| FLU2-40-1AD | V1 +5 | 0.0 | 3.00 | 5.00 | 1.0% | 0.2% | 1.0% | — | — | — |
| | V2 +12 | 0.0 | 2.00 | 3.00 | 5.0% | 0.5% | 3.0% | 4.0% | — | — |
| FLU2-40-3AD | V1 +5 | 0.0 | 3.00 | 5.00 | 1.0% | 0.2% | 1.0% | — | — | — |
| | V2 +24 | 0.0 | 1.00 | 1.50 | 5.0% | 0.5% | 3.0% | 4.0% | — | — |
| FLU2-40-4AD | V1 +5 | 0.0 | 3.00 | 5.00 | 1.0% | 0.2% | 1.0% | — | — | — |
| | V2 +28 | 0.0 | 1.00 | 1.00 | 5.0% | 0.5% | 3.0% | 4.0% | — | — |
| FLU2-40-7AD | V1 15(iso) | 0.0 | 1.50 | 2.50 | 1.0% | 0.2% | 1.0% | — | — | — |
| | V2 15(iso) | 0.0 | 1.20 | 2.00 | 3.0% | 0.5% | 1.0% | 1.0% | — | — |
| DC-DC Dual 36-75 VDC Input | | | | | | | | | | |
| DC2-40-1AC | V1 +5 | 0.0 | 3.00 | 5.00 | 1.0% | 0.2% | 1.0% | — | — | — |
| | V2 +12 | 0.0 | 2.00 | 3.00 | 5.0% | 0.5% | 3.0% | 4.0% | — | — |
| AC-DC Triples 85-265 VAC Input | | | | | | | | | | |
| FLU3-40-1AD | V1 +5 | 0.0 | 3.00 | 5.00 | 1.0% | 0.2% | 1.0% | — | — | — |
| | V2 +12 | 0.0 | 1.50 | 3.00 ³ | 5.0% | 1.0% | 3.0% | 4.0% | — | — |
| | V3 -12 | 0.0 | 0.50 | 0.70 | 5.0% | 0.2% | 1.0% | 1.0% | — | — |
| FLU3-40-2AD | V1 +5 | 0.0 | 3.00 | 5.00 | 1.0% | 0.2% | 1.0% | — | — | — |
| | V2 +12 | 0.0 | 1.50 | 3.00 ³ | 5.0% | 1.0% | 3.0% | 4.0% | — | — |
| | V3 -5 | 0.0 | 1.00 | 1.00 | 3.0% | 0.2% | 1.0% | 1.0% | — | — |
| FLU3-40-3AD | V1 +5 | 0.0 | 3.00 | 5.00 | 1.0% | 0.2% | 1.0% | — | — | — |
| | V2 +15 | 0.0 | 1.20 | 2.00 ⁴ | 5.0% | 1.0% | 3.0% | 4.0% | — | — |
| | V3 -15 | 0.0 | 0.50 | 0.60 | 5.0% | 0.2% | 1.0% | 1.0% | — | — |
| FLU3-40-4AD | V1 +5 | 0.0 | 3.00 | 5.00 | 1.0% | 0.2% | 1.0% | — | — | — |
| | V2 +24 | 0.0 | 0.75 | 1.50 ⁵ | 5.0% | 1.0% | 3.0% | 4.0% | — | — |
| | V3 -12 | 0.0 | 0.50 | 0.70 | 5.0% | 0.2% | 1.0% | 1.0% | — | — |
| FLU3-40-5AD | V1 5(iso) | 0.0 | 5.00 | 6.00 | 1.0% | 0.2% | 0.5% | — | — | — |
| | V2 12(iso) | 0.0 | 0.30 | 0.50 | 4.0% | 0.5% | 1.0% | 1.0% | — | — |
| | V3 12(iso) | 0.0 | 0.30 | 0.50 | 4.0% | 0.5% | 1.0% | 1.0% | — | — |
| FLU3-40-6AD | V1 5(iso) | 0.0 | 5.00 | 6.00 | 1.0% | 0.2% | 0.5% | — | — | — |
| | V2 15(iso) | 0.0 | 0.30 | 0.50 | 4.0% | 0.5% | 1.0% | 1.0% | — | — |
| | V3 15(iso) | 0.0 | 0.30 | 0.50 | 4.0% | 0.5% | 1.0% | 1.0% | — | — |
| DC-DC Triple 36-75 VDC Input | | | | | | | | | | |
| DC3-40-1AC | V1 +5 | 0.0 | 3.00 | 5.00 | 1.0% | 0.2% | 1.0% | — | — | — |
| | V2 +12 | 0.0 | 1.50 | 3.00 ³ | 5.0% | 1.0% | 3.0% | 4.0% | — | — |
| | V3 -12 | 0.0 | 0.50 | 0.70 | 5.0% | 0.2% | 1.0% | 1.0% | — | — |

POWER GENERAL

152 Will Drive · Canton, MA 02021 USA · Phone 781-828-6216 · Fax 781-830-1155 · Email power@nidecpg.com · http://www.nidec.com

40W

OPEN-FRAME SWITCHING POWER SUPPLIES

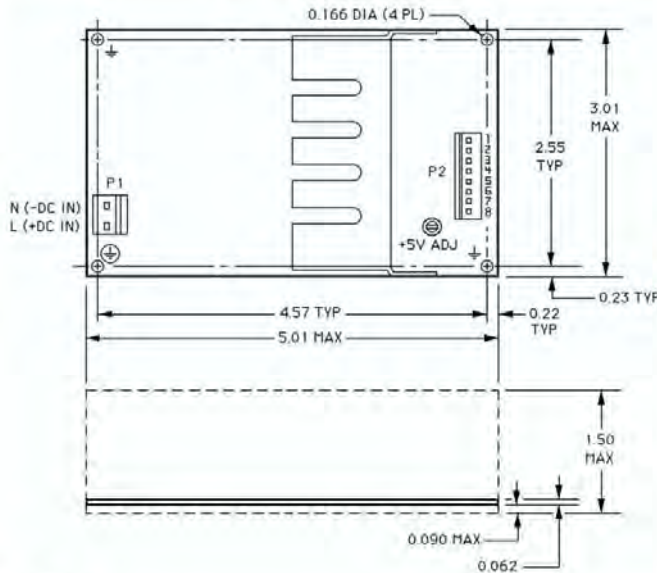

FLU AND DC 40W SERIES

- A. Dimensions shown are in inches.
- B. Tolerances = 0.00 ±0.01 inch.
0.000 ±0.005 inch.
- C. P1 input connectors are Molex 26-62-4030. The mating connector combines Molex housing 43061-0003 and crimp terminal 08-70-1030.
- D. P2 output connectors for the 40W series, except for models 5 and 6 of the FLU3-40 series, are Molex 26-60-4060. The mating connector combines Molex housing 43061-0006 and crimp terminal 08-70-1030. Models 5 and 6 of the FLU3-40 series use Molex 26-60-4080 for the P2 connector. The mating connector uses Molex housing 43061-0008 and crimp terminals 08-70-1030.

Pin-Out

| Pin | FLU1-40 | FLU2-40 Models 1, 3 | FLU2-40 Models 4, 7 | DC2-40 | FLU3-40 Models 1-4 | FLU3-40 Models 5-6 | DC3-40 |
|-----|---------|------------------------|------------------------|--------|-----------------------|-----------------------|--------|
| 1 | V1 | V2 | +V1(ISO) | V2 | V2 | +V2(ISO) | V2 |
| 2 | V1 | V1 | +V1(ISO) | V1 | V1 | - V2(ISO) | V1 |
| 3 | V1 | V1 | - V1(ISO) | V1 | V1 | +V1(ISO) | V1 |
| 4 | Return | Common | - V1(ISO) | Common | Common | +V1(ISO) | Common |
| 5 | Return | Common | - V2(ISO) | Common | Common | - V1(ISO) | Common |
| 6 | Return | N/C | +V2(ISO) | N/C | V3 | - V1(ISO) | V3 |
| 7 | N/A | N/A | N/A | N/A | N/A | +V3(ISO) | N/A |
| 8 | N/A | N/A | N/A | N/A | N/A | - V3(ISO) | N/A |

Notes

1. Replace the input line fuse with the same type and rating. Recommended: 2A/250V slow-blow fuse.
2. The sum of primary and auxiliary output currents from triple output models -1AD through -4AD must not exceed 5.0A.
3. Peak output current rating = 5.0A (<60 seconds, duty cycle <10%).
4. Peak output current rating = 3.0A (<60 seconds, duty cycle <10%).
5. Peak output current rating = 2.0A (<60 seconds, duty cycle <10%).
6. Electrical strength/isolation is 2200 VDC from the input of the power supply to ground for 60 seconds.
7. All measurements are made directly at the terminals of the power supply.
8. Peak-to-peak and RMS metering equipment must have a 20 MHz frequency response with probes and cables that maintain a frequency response of 20 Hz to 20 MHz. Output ripple and spikes are measured directly at the output terminals of the power supply with a 0.1 µF ceramic capacitor. The probe ground band must make direct contact with the output return or common terminal to prevent erroneous noise measurements.
9. MTBF is calculated using the parts stress method in MIL-HDBK 217F (ground benign, TA = +25°C).
10. Output voltage tolerance is measured under nominal load current conditions.
11. Line regulation is measured under nominal load conditions as the input voltage is varied from 85 to 265 VAC (ac-input models) or from 36 to 75 VDC (dc-input models).
12. Load regulation is measured at 115 VAC or 230 VAC. For single output models, load regulation is measured while output current is varied from 0% to 100% of full load. With multiple output models, the output under test is brought to 60% of nominal load; load current is then varied +40%/-30% of nominal while other outputs are held at nominal load conditions.
13. Cross-regulation is tested by changing the load on the primary output from 50% to 100% of nominal load while measuring the voltage change on the auxiliary output under test.
14. The FLU1-40, FLU2-40 and FLU3-40 series are approved to UL1950 (File E140439), CSA22.2 No. 234 (File LR52335), EN60950/IEC950/DIN VDE 0805 (TÜV Licenses R9679206, R9779161, R9779037), and Austel CCL (Certificate A92/PS/004).
15. The FLU3-40 series has BABT/EN41003 approval /4199/123/R/604674).
16. The DC2-40 and DC3-40 series are approved to UL1950 (File E140439), CSA22.2 No. 234 (File LR52335), and EN60950/IEC950/DIN VDE 0805 (TÜV License R9071501).