

Application of Continuous Resistivity Profiling to Aquifer Characterization

Donald D. Snyder
Zonge Engineering and Research Organization
Tucson, AZ
(520) 327-5501; skips@zonge.com

W. Ed Wightman
Blawkhawk Geosciences
Golden, CO

ABSTRACT

This paper presents the results of a continuous dipole-dipole resistivity survey conducted along a section of the Ohio River near Louisville, KY in the summer of 1997. Louisville, and no doubt many other municipalities along major rivers such as the Ohio River, draw their municipal water from the alluvium beneath the river using large vertical caissons from which horizontal perforated casings are pushed into the river. The high capacity of the pumping sites (200,000 gal/min) requires direct and rapid recharge of the drainage area of the intake site. Recharge rate and hence pumping capacity can be seriously compromised by the presence of clay on the river bottom directly over the intake drainage area retarding the recharge of the alluvium beneath. The objective of the resistivity survey was to characterize the nature of the river bottom for the purpose of siting new intakes for the municipal water supply of the city of Louisville. The paper describes a resistivity system assembled from commercially available ground resistivity instrumentation. Navigation information was coupled into the system using an integrated L-band differential GPS receiver. The equipment was installed and tested on a small pontoon barge powered by an outboard motor in less than a day. Using a streamer containing 9 electrodes spaced at 10-m intervals, 35 line-km of continuous dipole-dipole resistivity ($1 \leq n \leq 6$) data were acquired at approximate intervals of 5 m. The data were acquired in approximately 10 hours (3-5 km/hr) over a period of two 2 days. The resulting resistivity maps and pseudo-section profiles effectively delineate areas where clay is known to be present in the river bottom, detect the presence of culture (e.g., pipes and casing in the river bottom), and provide the basis for siting new water intake installations. The survey demonstrates that resistivity profiling provides a rapid and economical means for the characterization of sediments beneath shallow fresh water.

INTRODUCTION

The city of Louisville, KY and no doubt many other municipalities along the Ohio River draw their municipal water supply from wells located along the river that produce from unconsolidated sand and gravel that forms much of the river bed. The aquifer is recharged directly by the Ohio River and, therefore it serves as a sort of primary filter in the required steps for treatment and purification of the water. Figure 1 is a simplified geologic cross-section of the riverbank in the Louisville vicinity indicating the major geologic units and illustrating how the river water is produced. Water is actually produced from large-diameter caissons bored horizontally into the gravel layer under the river and which feed into a central vertical well from which water is pumped. At this site there exists localized Blue Mud that extends into the river and covers the gravel aquifer. This mud will likely have a detrimental effect on recharge of the gravel aquifer in its vicinity. Other geologic factors that need to be taken into account when placing a well are the aquifer thickness and porosity. As much as 200,000 gpm are produced from a single production caisson that may cost several million dollars to construct. A good site for a water

production caisson requires the presence of an adequate thickness of river sand and gravel and little or no Blue Mud to interfere with the recharge of the drainage area.

In the summer of 1997, ARCADIS Geraghty & Miller Inc. and Zonge Engineering and Research Organization conducted a towed-array resistivity survey along the southern bank of the Ohio River in the Louisville area. The objective of the survey was to characterize a section of the gravel aquifer along a 10 Km section of the river where production sites for the municipal water supply may be installed. This paper describes the instrument system assembled to conduct the survey and presents results from that survey.

SURVEY SYSTEM DESCRIPTION

The design of the survey system included the selection and fabrication of an electrode array, assembly of a resistivity acquisition system, and the selection of a navigation system. A modest budget dictated that the system must be assembled in less than one month from commercially available instruments and supplies.

Electrode Array Design

The dipole-dipole array was chosen for the electrode geometry because it eliminates the need for transmitter and/or receiver reference electrodes at the survey vessel. Furthermore the dipole-dipole array tends to balance both the signal and receiver wires thus reducing the effects of capacitive coupling caused by the presence of high-voltage transmitter lines running next to low-level signal lines. The dipole-dipole array also produces symmetrical responses over well-defined buried targets such as pipelines thus aiding their interpretation.

Selection of the electrode spacing for the dipole-dipole array (a-spacing) was based on estimates of the bulk resistivity and thickness of the major geologic units of interest: 1) river water (30 Ωm), 2) Blue Mud (10 Ωm), 3) sand and gravel aquifer (250 Ωm), and fractured limestone (50-500 Ωm).¹ Three-layer resistivity sounding curves published by Elliott (undated, IV, page 32) illustrate the behavior of the dipole-dipole apparent resistivity for the case of conductive clay overlying resistive gravel (Figure 2). The curves shown are for the case where the dipole spacing is equal to the depth of the first layer (water). In the case where conductive clay is present above the river gravel, the apparent resistivity is measurably less than the resistivity of the water for n-spacings of 1 and 2 even when the thickness of the clay layer is significantly less than one dipole spacing. These and other curves led us to conclude that the appropriate dipole spacing was 10 m, equal to the estimated mean depth of the river water over the survey area. By acquiring dipole-dipole resistivity measurements at several n-spacings, we expected to be able to detect even a few meters thickness of Blue Mud when it overlays the more resistive river gravel.

Description of Survey System

A block diagram of the survey system is shown in Figure 3. It includes four major subsystems:

1. Resistivity Measurement Subsystem
2. Streamer Cable System
3. DGPS Navigation Subsystem
4. Data Acquisition Subsystem

¹ Subsequent to the resistivity survey reported in this paper, TEM soundings suggest that the limestone is actually quite conductive. The TEM sounding data suggest resistivities in the range of 20-30 ohm-meters.

This system is described in more detail in a companion paper to this paper also presented at this conference. We refer you to that paper for more details.

Differential GPS (DGPS) Navigation Subsystem

Navigation information was provided by a Model SL-3000 Satellite-based differential GPS system manufactured by Satloc (Phoenix, AZ). The main advantage of this system is that it provides real-time sub-meter navigational accuracy. No post-processing was required and it was not necessary to establish a base station monitor onshore. The Satloc receiver was set up to transmit NMEA⁴ position messages upon receiving a command through its RS232C serial port. In addition, the Satloc also transmits RTCM differential correction information over a second serial RS232C port. We connected the RTCM port of the Satloc receiver directly to a Garmin 45XL handheld GPS receiver to provide a heads up display for navigation of the survey vessel while the survey was underway.

Data Acquisition Subsystem

Navigation information transmitted from the Satloc receiver and resistivity/IP data transmitted by the GDP-32 receiver were captured using a custom program developed by Zonge Engineering. The program operates under MS-DOS[®] from any PC-compatible platform having two COM ports. We used a Toshiba Satellite 2135CS laptop computer (25 MHz 486). Under control of this program, NMEA messages from the Satloc DGPS receiver and the resistivity and IP data strings from the GDP-32 are merged and stored into a single ASCII data file.

System Installation

The equipment diagrammed in Figure 3 and further described above was installed on a 25-ft pontoon barge powered by an outboard motor. Photographs of the barge, the installed equipment, and a view of the barge towing the streamer cable appear in Figure 4.

SURVEY DESCRIPTION

The survey was conducted along a 14-km stretch of the Ohio River immediately upstream from the city of Louisville. The survey location map, shown in Figure 5, shows extent of the entire survey. Only the downstream section of the survey is discussed here. Over a two-day period more than 35 line-km of data were acquired at a sample interval of approximately 5-m.²

Data Processing

Each block of resistivity data consists of the simultaneous measurement of 7 channels of resistivity data³ and relevant NMEA GPS position data including latitude, longitude, elevation, average speed and heading. Since positions are taken with respect to the antenna location some post processing was necessary in order to generate position information for each of the 9 electrodes in the UTM coordinate system. The UTM position for each electrode was generated by a program that reads a sample block⁴ from the raw field data and computes UTM positions based on the simple geometrical model shown in Figure 6.⁵ Note that the model assumes that the electrode streamer is a straight line with a heading identical to that of the towing vessel. This assumption is obviously violated during any change in course. However, provided all course changes are small ($< 5^\circ$) and undertaken slowly, the

⁴ NMEA – National Marine Electronics Association

² Boat speed was generally 3-4 km/hr and the sample interval was 5 seconds.

³ The 7 channels measured consisted of 6 standard dipole-dipole arrays ($1 \leq n \leq 6$) and the 20-m receiver dipole formed by the electrodes 6 & 8. During initial trials, we observed an intermittent connection in the cable at electrode 7 affecting the data acquired for $n=4$ and $n=5$. We decided to measure the 6-8 dipole which is approximately equal to $n=4.5$ to ensure that we had valid data at an n -spacing intermediate between $n=3$ and $n=6$.

⁴ A sample block consists of the resistivity and phase of each of up to 16 (max) receiver data channels together with the corresponding NMEA sentences containing the GPS position, velocity, and heading.

⁵ In subsequent surveys we modified our model for reducing the data. We presently use a curved track assumption as explained in the companion paper.

resulting errors in electrode position will be on the order of a few meters even at the last electrode (electrode 9) on the streamer. The resulting data file contains the UTM position for the plotting point (i.e., the mid-point between the transmitter dipole and the receive dipole), the n-spacing, the apparent resistivity, the phase, and the relative position along the line.⁶

Results

We show here a small section of the survey to illustrate the results. The section presented is the southern third of the 10 Km traverse. This section contains the strongest resistivity changes of the whole traverse and includes the region of known Blue Mud.

Figure 7 presents a contour map of showing the apparent resistivity data for the dipole-dipole data for $n=4.5a$. These data at the large n-spacing (4.5) are less affected by small variations in water depth. Therefore, in the absence of conducting clay, an apparent resistivity of 50-70 ohmmeters, representing about 25-30 percent of the true resistivity of the river gravels, is typical. By contrast, when just a few meters of conductive clay are present, the resistivity at $n=4.5a$ will be below 50 ohmmeters. Such behavior is seen in the Southern Section of the survey southwest of Zorne Avenue.

This map shows a resistivity high near the eastern banks of the river, bordering Cox Park. Measured resistivities here are over 75 ohmmeters. Farther west, towards the center of the river, the measured resistivities decrease, becoming fairly monotonous at about 45 ohmmeters. South of Zorne Avenue, the measured resistivities decrease significantly in one area to less than 25 ohmmeters. This is near the region where drill holes encountered Blue Mud.

One-Dimensional Interpretation

Data from this survey were interpreted using a layered resistivity model. Since water depths were obtained at a few locations, along with their GPS coordinates, these data were used in the interpretation. In order to obtain the resistivity of the river water, data were observed from the shallowest array geometry ($n=1$) over the deepest water available. This showed that the resistivity of the river water was about 28 ohmmeters. Layered interpretations were carried out using the known water depths, where available, along with 28 ohmmeters for the resistivity of the river water. In addition, a thin conductive layer was included at the base of the water to account for the mud at the bottom of the river. In this model the river water resistivity was fixed along with the thickness of the mud at 10 feet. The water thickness was not fixed because it was not possible to locate the exact position at which depths were obtained. Generally it was found that the interpreted thickness of the water was fairly close to the expected thickness. The remainder of the parameters were allowed to vary to obtain a solution. The main objective of this interpretation was to obtain conductive regions that may indicate Blue Mud along with the resistivity of the gravels, since this relates to porosity. Although gravel thickness is also important, this was not an objective for this particular survey. This would have required a longer electrode spread since the limestone bedrock is generally over 100 feet deep.

Figure 8 shows the interpreted water thickness from the sounding inversions. Comparing this map with Figure 7 generally shows an inverse relationship between measured resistivity and water thickness. This is expected with a resistive layer under the relatively conductive river water and thin mud layer. With shallow water the resistivity measurements are less influenced by the water and more by the resistive gravels, therefore showing a higher resistivity. The only area where this relationship does not apply appears to be south of Zone Avenue where a low resistivity region is shown on Figure 7 and deep water is indicated by Figure 8.

⁶ Position 0 on a line is defined as the mid-point between the transmitter dipole and the dipole for $n=1$ (electrodes 3 & 4). Position then increases in the direction of boat travel along line. Position is used for simple pseudo-section plotting.

Figure 9 presents an interpretation of the resistivity data using a layered model and shows the resistivity of the gravels. Resistivity inversion modeling was carried out as described above at each of the locations shown on the map as a small dot. North of Zone Avenue, the resistivity of the gravels increases towards the center of the river. Immediately north of Zone Avenue, a resistivity high is observed trending from the eastern riverbanks towards the center of the river. Thus, in this region, areas of deeper water correspond to higher gravel resistivities. The reason for this relationship is uncertain.

South of Zone Avenue is a significant region of low resistivity material interpreted to be Blue Mud. This area also corresponds to a localized increase in water thickness. Therefore, in this region, the relationship between water depth and gravel resistivity described above no longer applies.

Two-Dimensional Interpretation

Figure 10 shows the results of a smooth-model inversion (MacInnes and Zonge, 1996) of the resistivity for a portion of one of the measured profiles extending southwest from approximately Zone Avenue (see Figures 7-9). The results show a similar inverse relationship between the water depth and resistivity of the gravels except in the zone 12,350-12,800m SE. This zone is almost certainly influenced by the presence of a highly conductive cultural feature such as a pipe located near the interface between river water and the gravels or clay and centered about 12,400 m SE or, possibly, the presence of several barges moored along the side of the river. But the conductive zone extends considerably farther to the SE and coincides with an area where Blue Mud is known to exist.

Although water depths were not continuously recorded, they were manually logged together with their GPS positions at approximately 5-minute intervals. Generally speaking, along the section of the Ohio River that we surveyed, the water depths show no abrupt or rapid variations. The manually logged water depths were interpolated onto the station points for the profile section that was inverted in Figure 10. Using the two-dimensional inversion program with minor modifications that permitted us to hold the water layer resistivity and bottom topography nearly constant, we produced the resistivity cross-section shown in Figure 11. These results were generated by constraining the water-bottom geometry and the water resistivity using the *a priori* information provided from the water depth meter together with an estimate of the water resistivity.⁷ It is clear from these results that we need to further refine our techniques for constraining the model since the resulting model is noisy, particularly near the surface. It is clear, however, that any interpretation that constrains the surface layer to be of known resistivity and known geometry will be more geologically meaningful.

CONCLUSIONS

This survey has shown that collecting resistivity data over water for hydrologic investigations can be accomplished quickly and efficiently. With the use of real time differential GPS the location of the readings can be obtained to an accuracy of a meter or two. The data clearly outline a conductive region close to where the Blue Mud is expected and is interpreted to result from the Blue Mud. The survey has also determined the resistivity of the gravel aquifer under the river. This should be useful in estimating the porosity variations in the gravel and hence in determining locations for wells. A deficiency in the system we assembled was that the depth transponder was not connected into the data acquisition system. Any system that is assembled for the routine conduct of resistivity profiling from the surface of water bodies should, if at all possible, directly log both water depth and resistivity. Clearly, these data serve to substantially reduce the ambiguity of interpretation of the geoelectric section lying below the water bottom.

⁷ A water resistivity of 25 ohm-meters was used and was based on observed apparent resistivities as low as 25-26 ohm-meters measured in water depths of approximately 20m.

ACKNOWLEDGEMENTS

The authors would like to acknowledge the assistance of Bill Graves, Mykle Raymond, Scott MacInnes and Dexin Liu of Zonge Engineering for their assistance in conducting this survey. Bill Graves wrote the data acquisition program that merged the resistivity data with the GPS data. Mykle Raymond wrote most of the special data processing programs. Scott MacInnes modified his inversion program to handle the inversion of unusually long pseudo-section profiles. Dexin Liu generated both the pseudo-section plots and the resistivity map. Thanks also go to the Municipal Water Dept., City of Louisville, KY for permission to publish some of the data we acquired.

REFERENCES

- Elliot, Charles L., undated, Theoretical Response – Three Layered Earth: Tucson, AZ, Elliot Geophysical Company, V. II.
- MacInnes, Scott, and Zonge, Ken, 1996, Two-dimensional Inversion of Resistivity and IP Data with Topography: Presented at the 102nd Annual Northwest Mining Association Convention, Geophysics/Geochemistry – Session 1, Spokane, WA, December 3-6, 1996.

LIST OF FIGURES

- Figure 1: Simplified geologic cross-section of Ohio River near Louisville, KY showing major geologic units and illustrating how municipal water is pumped from the river bed.
- Figure 2: Theoretical response for a dipole-dipole array over a 3-layer earth (Elliott, undated, V. II, p. 32).
- Figure 3: System block diagram – Marine Resistivity/IP System.
- Figure 4: Photographs showing the survey system installation .
- Figure 5: Ohio River Resistivity Survey – Location Map.
- Figure 6: Assumed geometry and mathematical expressions for calculating electrode position from GPS antenna location.
- Figure 7: Dipole-dipole ($a = 10$ m) apparent resistivity map for $n=4.5$. Data shown are for a section of the survey.
- Figure 8: Water depth map based on 1-D interpretations of dipole-dipole ($a = 10$ m) apparent resistivity for lower section of survey.
- Figure 9: Interpreted riverbed resistivity based on 1-D interpretations of dipole-dipole ($a=10$ m) apparent resistivity for a portion of the survey.
- Figure 10: Two-Dimensional smooth model inversion of dipole-dipole apparent resistivity for the section of survey profile indicated on Figures 7-9.
- Figure 11: Two-dimensional constrained smooth model inversion of dipole-dipole apparent resistivity for the section of survey profile indicated on Figures 7-9.

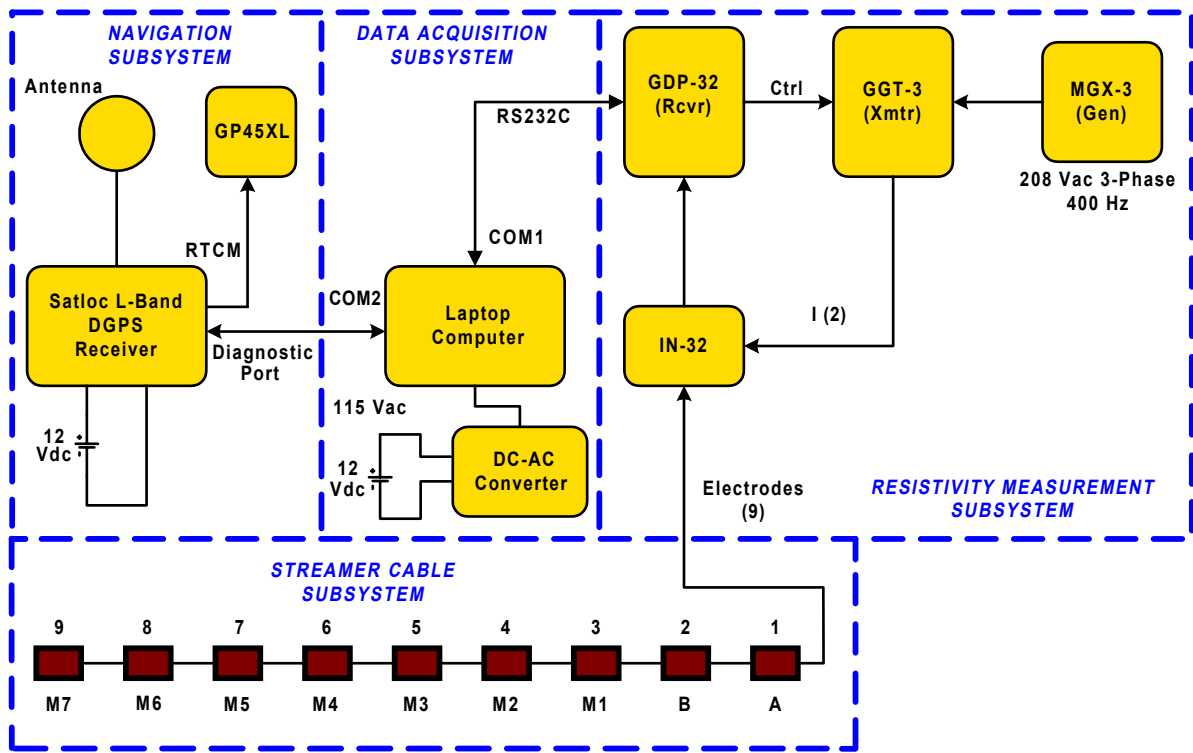

Figure 3: System block diagram - Marine Resistivity/IP System.



Figure 4: Photographs showing the survey system installation

Ohio River Resistivity Survey

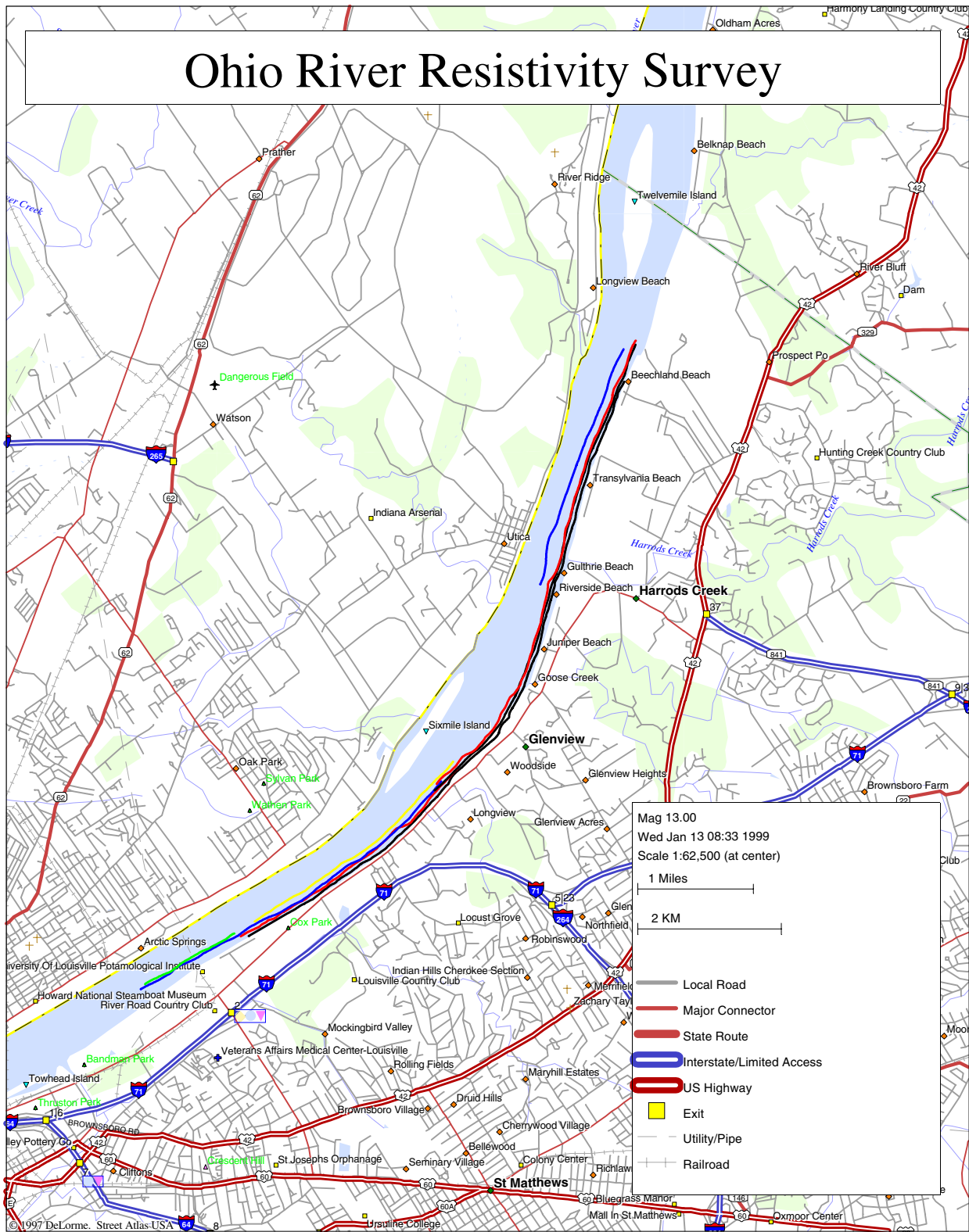

Figure 5: Ohio River Resistivity Survey - Location Map

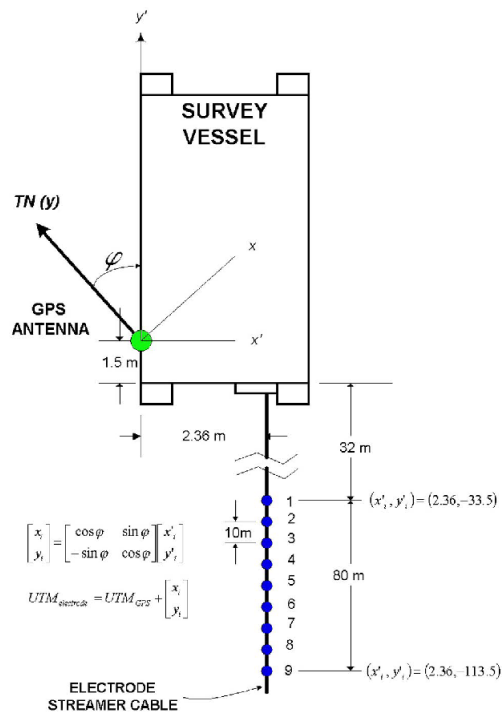

Figure 6: Assumed geometry and mathematical expressions for calculating electrode position from GPS antenna location.

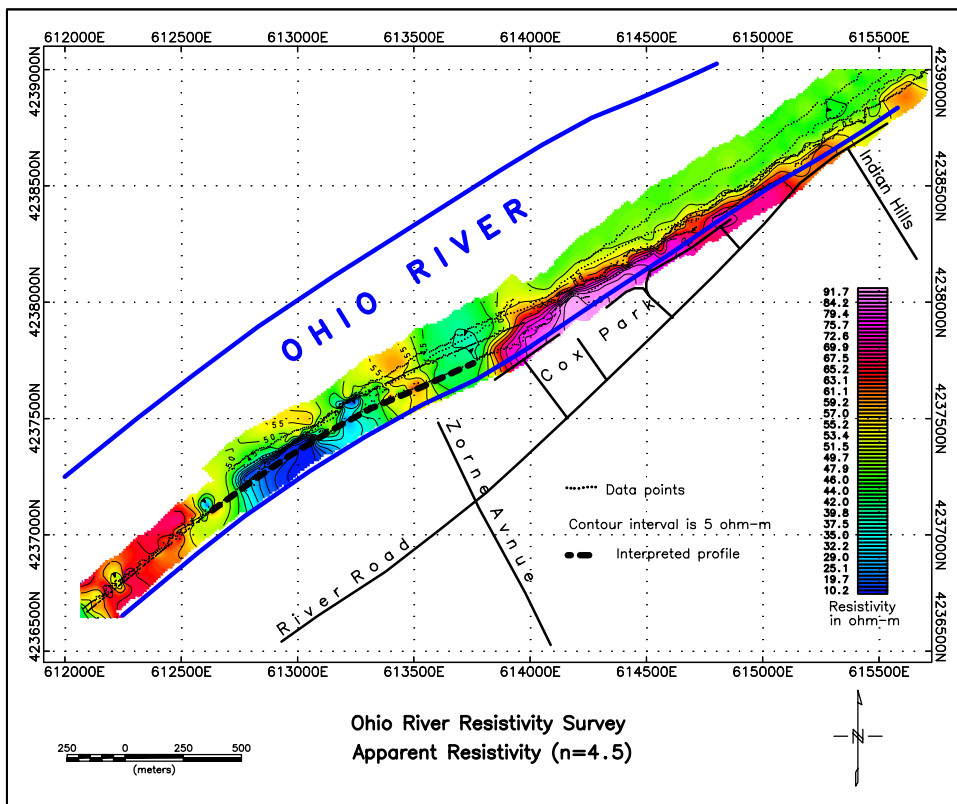

Figure 7: Dipole-dipole ($a = 10$ m) apparent resistivity map for $n=4.5$. Data shown are for a section of the survey

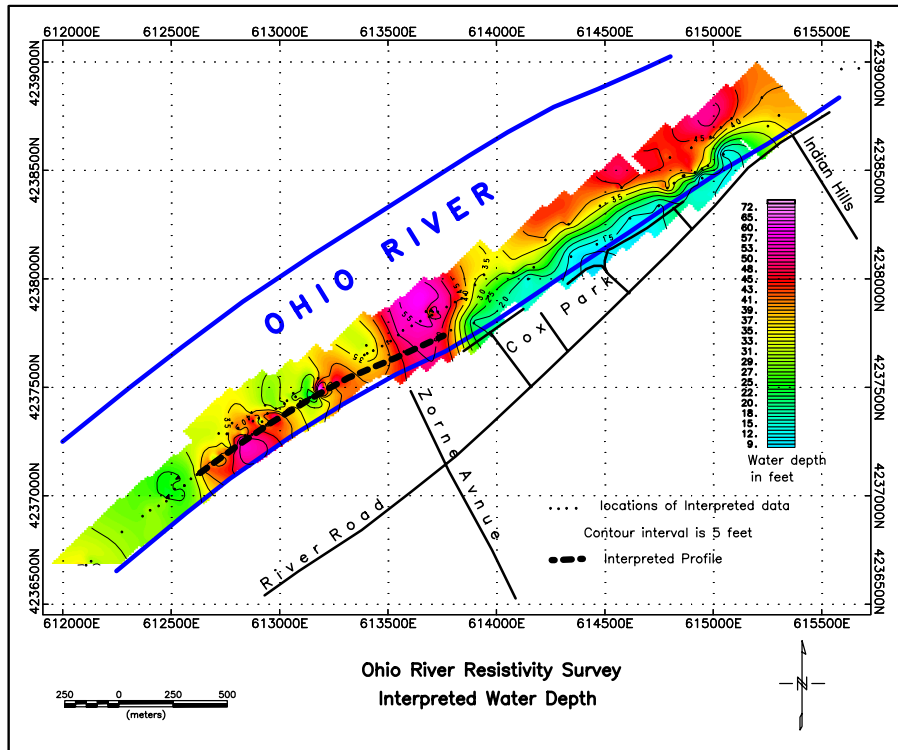

Figure 8: Water depth map based on 1-D interpretations of dipole-dipole ($a = 10\text{m}$) apparent resistivity for lower section of survey.

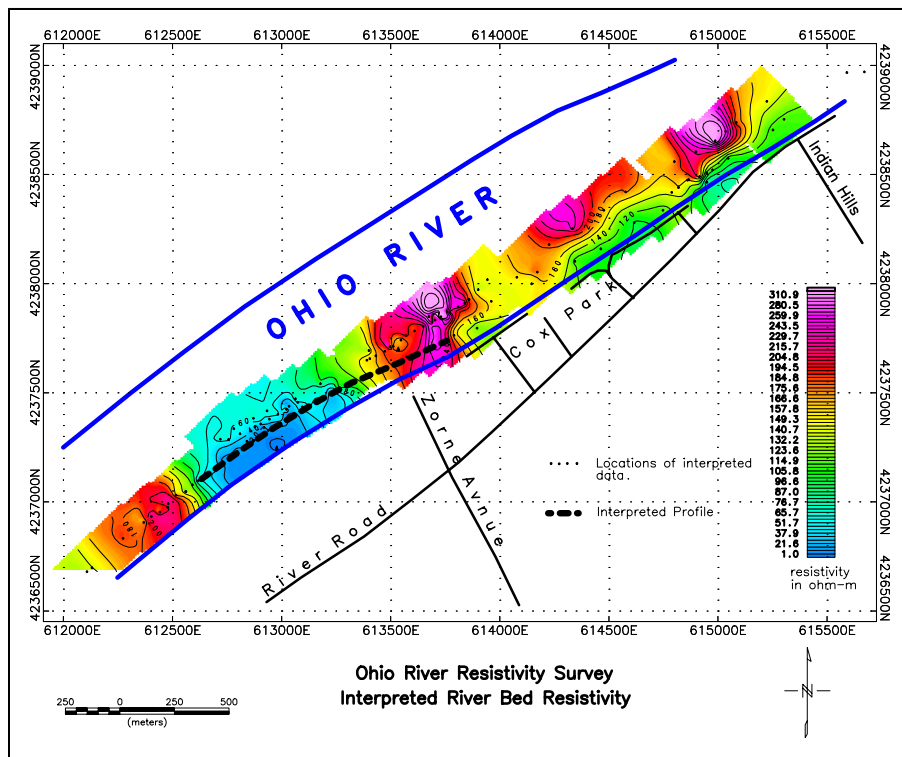

Figure 9: Interpreted river bed resistivity based on 1-D interpretations of dipole-dipole ($a=10\text{m}$) apparent resistivity for a portion of the survey.

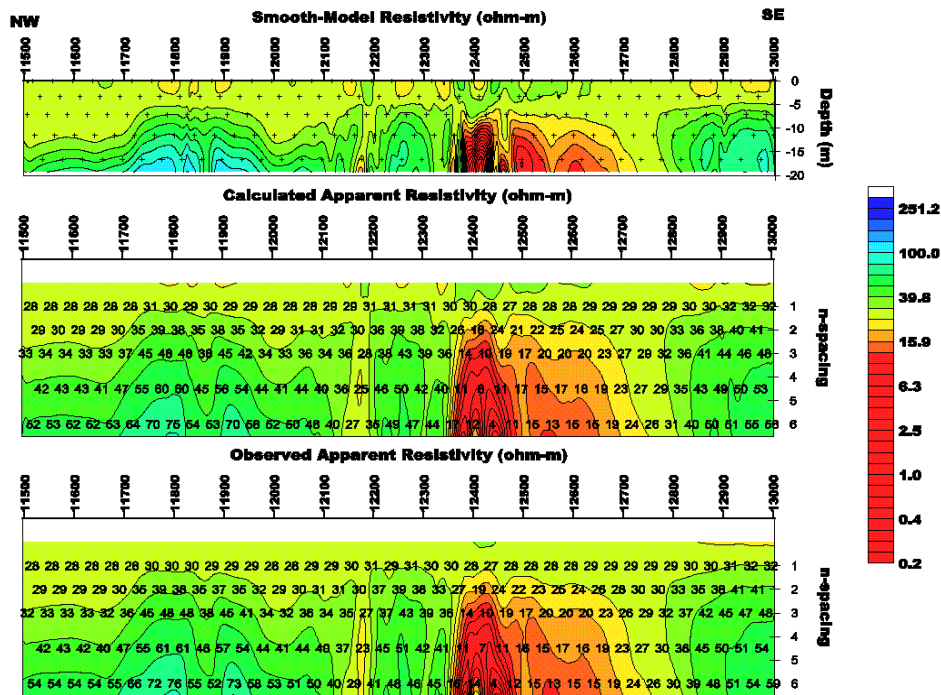

Figure 10: Two-Dimensional smooth model inversion of dipole-dipole apparent resistivity for the section of survey profile indicated on Figures 7-9.

Ohio River Resistivity Survey Smooth Model Inversion Results

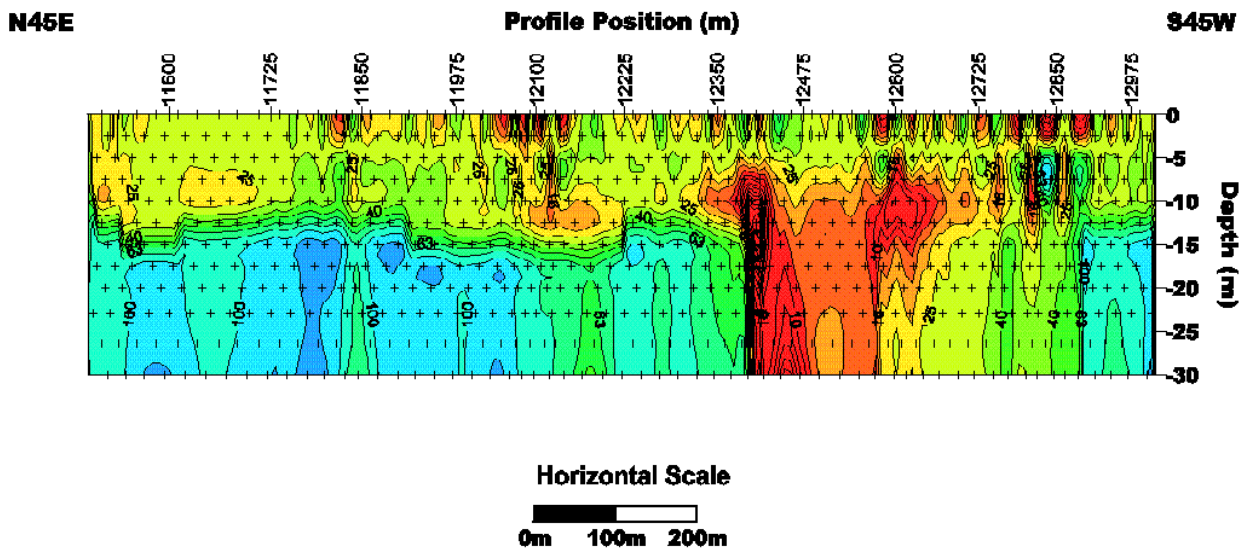

Figure 11: Two-dimensional constrained smooth model inversion of dipole-dipole apparent resistivity for the section of survey profile indicated on Figures 7-9.