

THE MX-30

Multiplex Switch

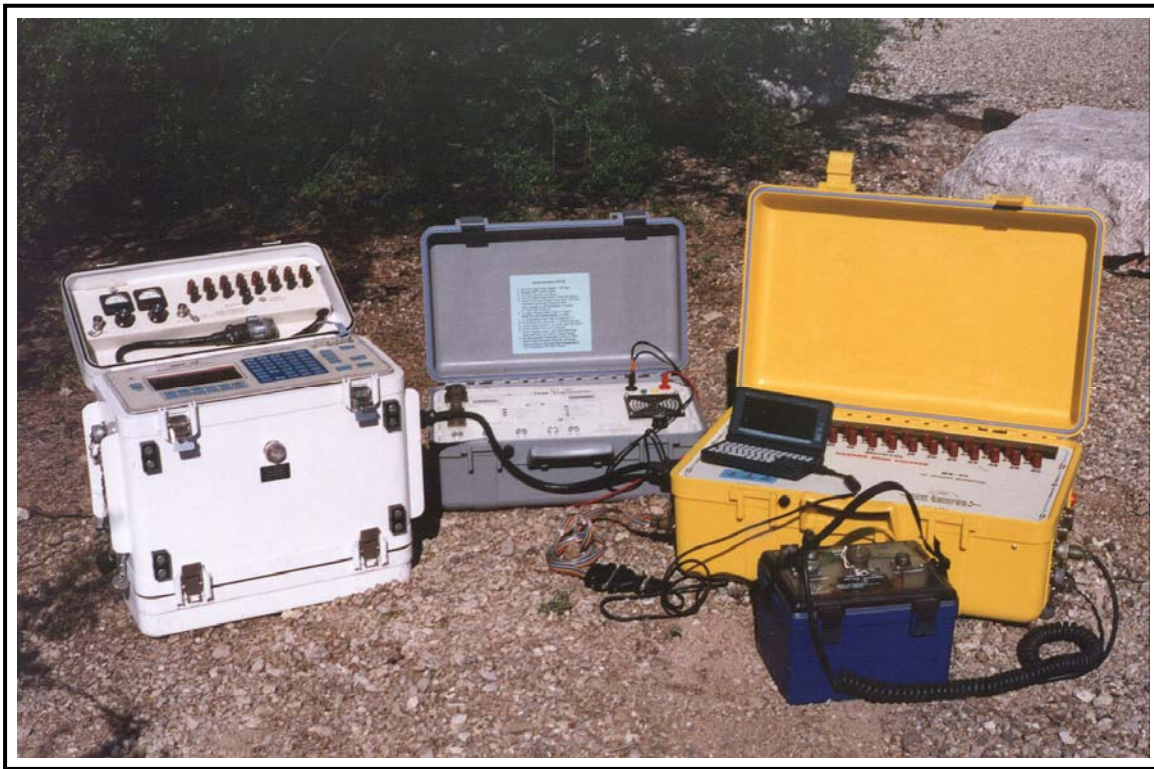

DESCRIPTION

The MX-30 was developed to provide a computer-controlled switching interface between a transmitter, a multi-channel receiver such as the GDP-32^{II}, and an array of electrodes. The MX-30 features a transmitter input multiplexer which can connect the transmitter leads to any pair of electrodes. A receiver multiplexer permits the operator to select any number of electrode pairs (up to half the number of electrodes) for input to the receiver. Multiplexer configuration is controlled by commands transmitted over an RS-232C serial communications channel. A control program is available for a laptop computer. The MX-30 is an essential component of any system designed to rapidly acquire resistivity data using cabled electrode arrays. Customers are currently using the MX-30 together with a GDP-32^{II} receiver and a ZT-30 transmitter to gather data for **Electrical Resistivity Tomography**. The MX-30 can be configured to provide fewer channels at a reduced cost. The unit can be upgraded in the field at a later date to give it increased output channel capacity.

FEATURES

- Selectable Electrode String – 30 electrodes Max
- External Control – RS-232C Serial (4800,N,8,1)
- Signal Output Channels (differential) – 16 Max
- Transmitter Output Relay Specs - ± 500 Vdc 5 A
- Transmitter/Receiver Channel Isolation – 1000V
- High Speed Optical Relays on Receiver MUX
- Fully compatible with GDP-32^{II} Receiver
- MX-30's may be cascaded together to address several electrode arrays

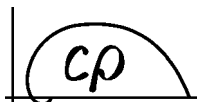

Zonge Engineering and Research Organization, Inc.

Specialists in Electrical Geophysics

• Field Surveys • Geophysical Consulting • Instrumentation Sales and Lease •

SPECIFICATIONS FOR THE MX-30 MULTIPLEXOR

Mechanical Characteristics

Enclosure: Heavy-Duty Environmentally Sealed
ABS Plastic Case
Size: 55 x 23 x 37 cm (22 x 9 x 15 in)
Weight: 16 kg (35 lb)

Electrical Characteristics

Transmitter Multiplexer: 500 Vdc (max); 5 A (max)
Signal Multiplexer: ± 18 Vdc

Controls & Displays

Power ON / OFF switch
LED indicators for:
POWER ON, SERIAL DATA, and CPU

Power

External battery: 10-14 Vdc
(6 Amp-hr recommended)

I/O Connectors

External Battery
RS-232C IN
RS-232C OUT
RS-485 IN
RS-485 OUT
Signal Channels 1-8
Signal Channels 9-16
TX Current IN
Electrodes IN (1-30)

Applications

Electrical Resistance Tomography
Automated Resistivity Soundings
Automated Dipole-Dipole Resistivity/IP Profiling

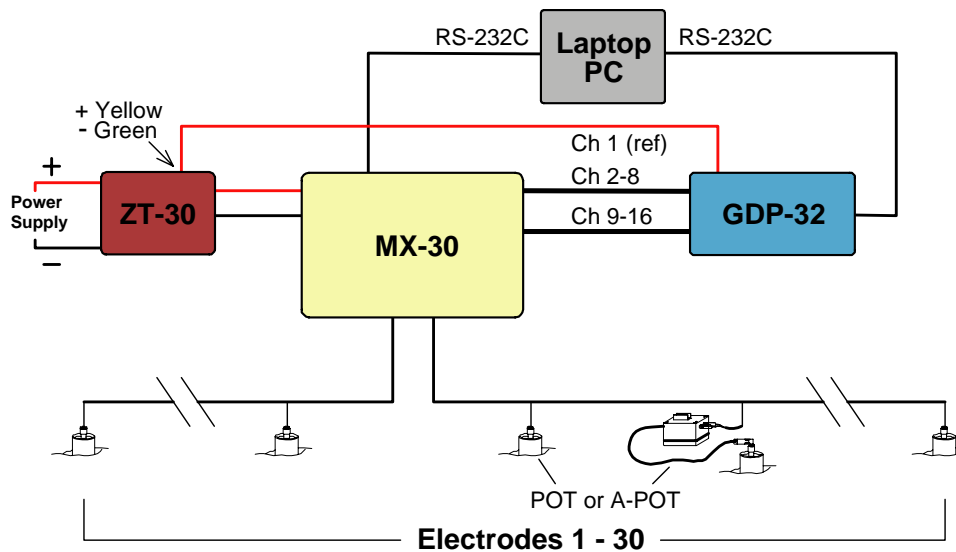

Specifications subject to change without notice
© Copyright 2005, Zonge Engineering & Research Organization, Inc.



Zonge Engineering and Research Organization, Inc.

Offices:

Arizona, Alaska, Nevada, Colorado and Minnesota

Headquarters:

3322 E. Ft. Lowell Road, Tucson, AZ 85716, USA (800) 523-9913
Tel: (520) 327-5501 Email: zonge@zonge.com
Fax: (520) 325-1588 Web: <http://www.zonge.com>